

Eliteboard

User Guide

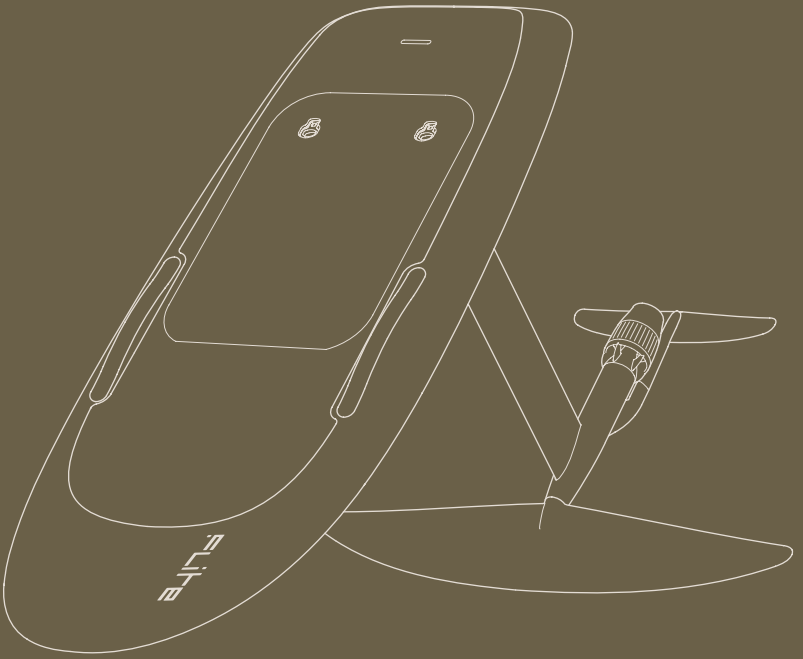

Product Activation

BEFORE USE, THIS PRODUCT MUST BE ACTIVATED USING THE FLITE APP.
fliteboard.com/app

Important

IN ORDER TO OPERATE THE PRODUCT CORRECTLY AND MINIMISE THE CHANCES OF DAMAGE, SERIOUS INJURY OR DEATH, IT IS ESSENTIAL TO READ AND FOLLOW ALL OF THE INSTRUCTIONS AND WARNINGS IN THE USER GUIDE PRIOR TO ASSEMBLY, SETUP OR USE. BY USING A FLITEBOARD YOU AGREE THAT YOU DO SO AT YOUR OWN RISK.

CAUTION - THIS PRODUCT HAS BEEN KNOWN TO DRAMATICALLY IMPROVE YOUR LIFE AND HAPPINESS LEVELS.



For the latest version and translations of this guide visit

fliteboard.com/support



Watch our video tutorials at

fliteboard.com/video



Authorised Flite Dealers and Fliteschools

fliteboard.com/locations



Download the Flite App

fliteboard.com/app



Fliteboard support

fliteboard.com/support



Fliteboard contact

fliteboard.com/contact



Material Safety Data Sheets

fliteboard.com/MSDS



Ready to fly post storage checklist

fliteboard.com/readytoflychecklist



6 Month Flitecell Checklist

fliteboard.com/flitecellchecklist

Fliteboard User Guide

6 Safety and Disclaimer

- 6 Warning
- 6 Intended use
- 7 Propulsion system
- 7 Hydrofoil safety
- 7 Learning to Fliteboard
- 8 Important rider safety

10 Flitecell

11 Warranty and Compliance

- 11 Warranty
- 11 Repairs
- 11 Shipping compliance

12 What makes up a Fliteboard

- 12 Fliteboard
- 13 Flitecell
- 14 Flite eFoil
- 16 eFoil packaging
- 17 Accessories pouch
- 18 Flite conical wings
- 19 Rear stabiliser

20 Getting started

- 20 Charging Flite Controller
- 21 Charging MN Flite Controller
- 22 Flitecell charging procedure
- 22 Flitecell Indicator Guide
- 23 Charging Flitecell
- 24 Inflating AIR

- 26 Connect the eFoil to Fliteboard
- 27 Connect the wing
- 28 Connect the fuselage tail
- 29 Connect the stabiliser wing
- 30 Pro Tail Cover installation
- 33 Dual Drive for Prop C
- 34 Flite x Mercury Racing impeller
- 35 RACE handles installation
- 36 Connect Flitecell to Fliteboard

- 37 Turning on Flitecell
- 38 Download Flite App and update
- 38 Connecting Flite App to Fliteboard
- 39 Capturing sessions
- 39 Flite Controller overview
- 39 MN Flite Controller overview
- 40 Turn on Flite Controller
- 40 Connecting Flite App to Flite Controller
- 41 Flite Controller pairing procedure
- 43 Ride settings
- 45 Flite Controller screens
- 49 MN Flite Controller screens

53 Get Fliteboarding

- 53 Fliteboard safety aids
- 53 Select a suitable riding location
- 54 Arming the motor
- 55 Engage the motor and get moving
- 56 Getting to your knees
- 57 Standing up
- 58 Fliteboarding for the first time

59 Fliteboarding pro tips

- 59 Foiling through turns

60 Maintenance and storage

- 61 ICON, PRO, ULTRA, MN, RACE
- 62 AIR
- 63 Flite Controller

63 Flitecell

65 Troubleshooting

- 67 Technical specifications
- 72 Warranty registration / Details of purchase
- 74 Maintenance schedule

Safety and Disclaimer

All safety and disclaimer information is subject to change at the sole discretion of Fliteboard. For up-to-date product information visit fliteboard.com/support

Warning

Failure to operate this product in a safe and responsible manner could result in injury or death to yourself or others and/or damage to the Fliteboard or other's property.

THIS PRODUCT MUST BE OPERATED WITH CAUTION AND COMMON SENSE AND REQUIRES SOME BASIC MECHANICAL ABILITY.

FLITEBOARD IS NOT INTENDED FOR USE BY CHILDREN UNDER 16 YEARS OF AGE, SUBJECT TO LOCAL LAWS AND REGULATIONS.

DO NOT USE WITH INCOMPATIBLE COMPONENTS OR ALTER THIS PRODUCT IN ANY WAY OUTSIDE OF THE DOCUMENTS PROVIDED BY FLITEBOARD.

FLITEBOARD IS NOT A TOY. EXERCISE CAUTION. ACT RESPONSIBLY WHILE OPERATING.

CONSIDER THE SAFETY OF YOUR ENVIRONMENT BEFORE OPERATING FLITEBOARD. DO NOT RIDE IN SHALLOW WATER (LESS THAN 1.5M IN DEPTH), ROCKY AREAS OR IN SEVERE WEATHER CONDITIONS.

IT MAY BE NECESSARY TO OBTAIN A LICENCE OR PERMIT TO USE A FLITEBOARD IN CERTAIN STATES OR COUNTRIES.

Intended use

Fliteboard is for operation by one person only, who should be over the age of 16 (or as local laws apply). It is not designed for passengers or towing of objects or people. Please check your local regulations for age and legal requirements. We recommend adult supervision. Licence regulations vary from state to state and country to country. For example, in Australia, Fliteboard is exempt from registration in some states, and in others it must be registered as a vessel. It is the responsibility of riders to be aware of and comply with regulations in their specific location.

Fliteboard must travel at a safe speed so that Fliteboard can be stopped in time to avoid any danger which may suddenly arise. When judging a safe speed, you must consider a number of factors - visibility, other vessels, navigation hazards, wind, waves and currents, waterway width and the manoeuvrability of your vessel.

For your safety and that of others, please ensure that you obtain proper training or practice before operating Fliteboard yourself.

This User Guide does not provide boating safety or seamanship advice. Please consult local laws and guidelines for boating safety.

If you have any questions about the operation or maintenance of Fliteboard, please consult Fliteboard technical support, or a Flite Dealer.

This User Guide should be considered a permanent part of Fliteboard and should remain with it even if it is subsequently sold.

Propulsion system

The Fliteboard propulsion system includes a powerful spinning Flite Propeller or Flite Jet.

KEEP BODY, FINGERS AND TOES AWAY FROM THE FLITEBOARD'S SPINNING PROPELLER OR IMPELLER. CONTACT WITH THE PROPELLER OR IMPELLER WILL CAUSE SERIOUS INJURY OR DEATH.

NEVER TOUCH THE PROPELLER OR IMPELLER IN OR OUTSIDE OF THE WATER.

NEVER HANDLE THE PROPELLER OR IMPELLER WHILE THE FLITECELL IS CONNECTED.

ALWAYS FLITEBOARD A SAFE DISTANCE FROM OTHER WATERCRAFT, SWIMMERS, SURFERS, DIVERS AND WILDLIFE.

NEVER FLITEBOARD IN SEAWEED OR CONTAMINATED WATER.

Hydrofoil safety

The Fliteboard hydrofoil system comprises a mast (or strut), a main wing and stabiliser wing. These components include sharp trailing edges and wing tips. Take care not to kick or hit the sharp edges when in the water.

FALLING ON THE HYDROFOIL CAN CAUSE SERIOUS INJURY OR DEATH.

WE ALWAYS RECOMMEND YOU WEAR APPROPRIATE SAFETY GEAR WHEN FLITEBOARDING, INCLUDING AN APPROVED IMPACT VEST / PFD AND HELMET. CHECK YOUR LOCAL REGULATIONS TO CONFIRM IMPACT VEST / PFD AND HELMET REQUIREMENTS. REFER TO THE MANUFACTURER'S DOCUMENTATION ON SAFETY, CARE AND MAINTENANCE GUIDELINES FOR YOUR IMPACT VEST / PFD AND HELMET.

TAKE CARE TO LEARN STEP BY STEP, FOLLOWING THE INSTRUCTIONS IN THIS GUIDE AND THE GUIDES SECTION OF THE FLITE APP.

fliteboard.com/app

Learning to Fliteboard

We recommend learning to Fliteboard with an instructor at an authorised Fliteschool. Fliteschool locations can be found at fliteboard.com/locations

PLEASE VIEW OUR HOW TO FLITEBOARD VIDEO AT fliteboard.com/video TO LEARN THE PROPER TECHNIQUE AND REVIEW RIDING SAFETY INFORMATION.

FLITEBOARD IS NOT SUITABLE FOR RIDING BREAKING WAVES IN THE SURF ZONE. RIDERS DO SO AT THEIR OWN RISK. FLITEBOARD SHOULD NEVER BE RIDDEN NEAR OTHER WATER USERS (INCLUDING SWIMMERS AND SURFERS) OR OFFSHORE FROM SWIMMERS AND SURFERS (IN CASE FLITEBOARD IS PUSHED TOWARDS SHORE IN A WAVE).

FLITEBOARDING CAN BE EASY WHEN PROPER TECHNIQUE IS APPLIED. INCORRECT TECHNIQUE CAN RESULT IN INJURY OR DAMAGE.

DO NOT CLEAN THE FLITECELL OR CHARGER WITH WD-40, CITRUS CLEANERS, CONTACT CLEANERS.

AVOID CONTACT WITH SUNSCREENS, LUBRICANTS, PETROL, THREAD LOCKER, AND DIESEL.

Important rider safety

1 Read the User Guide and watch the How to Fliteboard video

Before attempting to Fliteboard for the first time, read this User Guide and pay special attention to the warnings and disclaimers. Most injuries can be avoided by using proper technique when learning. Watch the How to Fliteboard videos in the Guides section of the app. fliteboard.com/app



2 Wear a helmet and Impact Vest / PFD

Wear an approved and certified helmet and impact vest / PFD (Personal Flotation Device) at all times.

There may be specific rules and legal requirements in your location that also apply.

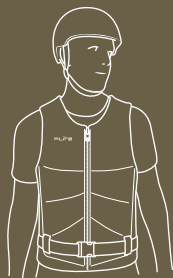

3 Avoid contact with the wings and propeller

Avoid contact with the wings, mast and propeller which all have sharp edges. Take care to not kick the wings when climbing on to the board.

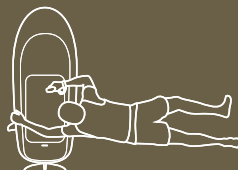

4 Keep distance

Keep well clear of other water users at all times. Check regulations for vessel operating distance rules in your area. Always be on the lookout for swimmers, divers, other vessels or obstacles when riding; they may be obscured by waves or glare.



200 m

5 Release the throttle

Release the throttle trigger immediately on committing yourself to a fall. This will stop the motor and reduce the forces which could otherwise lead to a more extreme crash. Practice this skill when learning with the goal of stopping the motor before you hit the water in a fall.

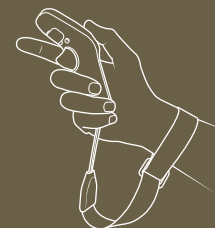

6 Fall away from Fliteboard

The best way to avoid injury is to practice the correct falling technique. As soon as you begin to lose balance, purposely fall in the direction the board is already falling. You will then likely end up in the water on the opposite side to the hydrofoil assembly. Like being on stilts, it is impossible to regain balance once your weight is no longer above the hydrofoil wings (unless you are turning).

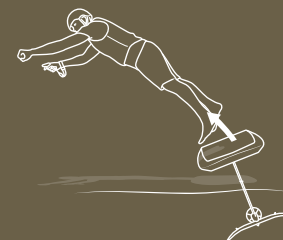

Flitecell

Flitecell is a carefully engineered water resistant marine battery. If the Flitecell is damaged (for example during transportation or handling) the seal may become compromised. A damaged Flitecell that comes into contact with water may result in internal damage including corrosion which could result in a fire and/or explosion.

USE FLITECELL AT YOUR OWN RISK.

SIGNS OF A COMPROMISED FLITECELL

- SIGHT GLASS LABEL HAS TURNED RED, INDICATING WATER INGRESS
- LOOSE SCREWS/RIVETS
- CONNECTOR COMING LOOSE
- CRACK IN HOUSING/CASE
- DEFORMATION
- UNUSUAL SMELL
- HIGH TEMPERATURE DURING CHARGING (60°C OR MORE)

CAREFULLY INSPECT FLITECELL BEFORE EACH USE.

IF A FLITECELL CASING HAS VISIBLE DAMAGE AND THE FLITECELL FALLS INTO WATER, TAKE IT OUT IMMEDIATELY AND PUT IT IN A SAFE AND OPEN AREA. MAINTAIN A SAFE DISTANCE FROM FLITECELL UNTIL IT IS COMPLETELY DRY. DO NOT USE FLITECELL AGAIN AND DISPOSE OF FLITECELL PROPERLY.

FLITECELL MUST BE USED IN TEMPERATURES FROM 0°C TO 40°C. USE OF FLITECELL IN ENVIRONMENTS ABOVE 40°C MAY LEAD TO AN OVERHEATED BATTERY. USE OR CHARGING OF FLITECELL BELOW 0°C CAN LEAD TO PERMANENT FLITECELL DAMAGE.

ALWAYS KEEP FLITECELL DRY. IF FLITECELL HAS BEEN EXPOSED TO WATER, PLACE IN A COOL DRY PLACE.

DO NOT DROP OR STRIKE FLITECELL.

DO NOT PLACE HEAVY OBJECTS ON FLITECELL OR THE CHARGER.

DO NOT USE FLITECELL TO OPERATE ANY DEVICE OTHER THAN FLITEBOARD.

DO NOT CHARGE OR USE A DAMAGED FLITECELL. IF YOUR FLITECELL IS COMPROMISED, CONTACT FLITEBOARD OR A FLITE SERVICE DEALER FOR FURTHER ASSISTANCE.

DO NOT USE FLITECELL IF IT WAS INVOLVED IN A SEVERE CRASH OR HEAVY IMPACT.

DO NOT USE A NON FLITECELL BATTERY. ANY DAMAGE CAUSED BY A NON-OFFICIAL BATTERY WILL NOT BE COVERED BY WARRANTY.

DO NOT DISASSEMBLE FLITECELL. DOING SO COULD CAUSE AN INJURY OR LEAD TO A WATER LEAK OR FIRE. TAMPERING WITH THE FLITECELL BATTERY WILL VOID THE WARRANTY.

DO NOT HEAT FLITECELL. KEEP AWAY FROM HEATING SOURCES AND OUT OF DIRECT SUNLIGHT.

DO NOT PUT FLITECELL IN A MICROWAVE OVEN, FREEZER OR IN A PRESSURISED CONTAINER.

DO NOT OPEN FLITEBOARD LID UNDER ANY CIRCUMSTANCES WHILST IN WATER OR WITH WET HANDS.

IN CASE OF A FLITEBOARD OR FLITECELL FIRE, EXTINGUISH WITH COLD WATER WITHOUT ADDITIVE.

FOR FURTHER INFORMATION ABOUT INCIDENT RESPONSE AND DISPOSAL, PLEASE REFER TO THE MATERIAL SAFETY DATA SHEET (MSDS).

DISPOSE OF THE FLITECELL IN SPECIFIC RECYCLING BOXES ONLY AFTER A COMPLETE DISCHARGE. DO NOT PLACE FLITECELL IN REGULAR TRASH CONTAINERS. STRICTLY FOLLOW YOUR LOCAL REGULATIONS REGARDING THE DISPOSAL AND RECYCLING OF BATTERIES.

DO NOT CLEAN THE FLITECELL OR CHARGER WITH WD-40, CITRUS CLEANERS, CONTACT CLEANERS.

AVOID CONTACT WITH: SUNSCREENS, LUBRICANTS, PETROL, THREAD LOCKER, AND DIESEL.

Warranty

Fliteboard comes with a Limited 2-year Warranty which covers defects in materials or workmanship of the product and aligns to relevant consumer laws of the location of purchase. Further details about the Fliteboard Limited Warranty are set out in your Purchase Agreement and on our website.

For our Australian customers – our goods come with guarantees that cannot be excluded under the Australian Consumer Law. You are entitled to a replacement or refund for a major failure and compensation for any other reasonably foreseeable loss or damage. You are also entitled to have the goods repaired or replaced if the goods fail to be of acceptable quality and the failure does not amount to a major failure.

Product Registration for Warranty now recorded in the FLITE APP

Maintaining your Fliteboard

Fliteboard is much more than a surfboard. Similar to any other electric powered vehicle, it needs to be serviced regularly and maintained to ensure good working order and to prevent breakage.

In order to maintain your Fliteboard in optimal condition, a 100 hrs / yearly service of the eFoil is recommend and/or a warranty requirement (depending on your eFoil propulsion system).

To find your nearest Flite Service Dealer, visit fliteboard.com/locations

Fliteboard has been extensively tested with riders weighing up to 120kg / 265lbs. Our specified limit for warranty is defined in the Technical specifications section of this User Guide.

Information about recommended wing and board combinations for beginner and experienced riders, and lighter and heavier riders, can be found at fliteboard.com/support

For full comprehensive storage and maintenance instructions, visit the support portal fliteboard.com/support

Servicing requirement for valid warranty

Prop C, MN Carbon Dual Drive, MN Carbon Prop C and MN Carbon Wave C require servicing every **100 hours or 1 year, whichever comes first.**

Jet C, Flitescooter C and MN Carbon Jet C (all systems with Flite Jet 2), require servicing every **200 hours or 2 years, whichever comes first.**

Carefully pack the eFoil and Flite Controller in the original eFoil Travel Bag including foam inserts. Send to a Flite Service Dealer or Fliteboard HQ (whichever is closest). Flitecell, wings, chargers or other accessories are not required and should not be included.

Please refer to our 'Packing your Fliteboard' video and help documentation via fliteboard.com/support

Repairs

If subjected to damage, ICON, PRO, ULTRA, MN and RACE can be repaired by your local surfboard repair specialist. Inflatable AIR may be repaired using the included repair kit.

Shipping compliance

Shipping batteries can be illegal and dangerous if not done in accordance with dangerous goods shipping regulations. Always consult an appropriate specialist before shipping your Flitecell. Refer to the included MSDS regarding shipping your Flitecell by sea.

What makes up a Fliteboard

You will receive your Fliteboard in separate shipment packages.

Fliteboard

You will receive a Fliteboard of the model, size and colour of your choice in a board bag. AIR ICON and AIR PRO board bags need to be ordered separately.

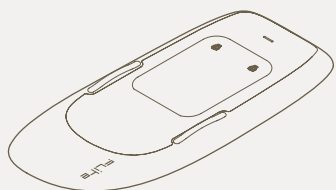

ICON

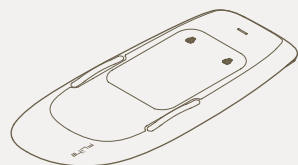

PRO

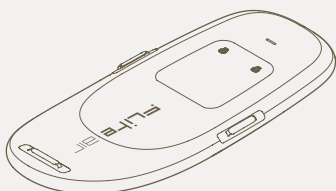

AIR ICON

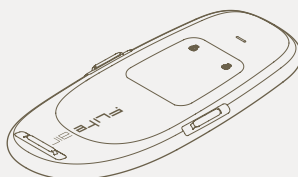

AIR PRO

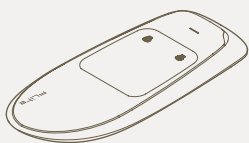

ULTRA L3

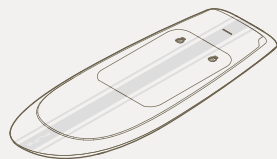

RACE

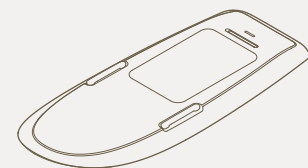

MN86

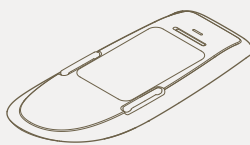

MN60

Flitecell

Within the included padded Flitecell bag you will find Flitecell Explore, Flitecell Sport or Flitecell Nano, depending on your choice.

ULTRA L2 & L3, AIR ICON AND AIR PRO ARE NOT COMPATIBLE WITH FLITECELL EXPLORE.

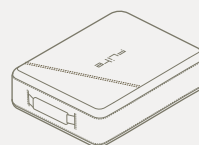

Flitecell travel bag

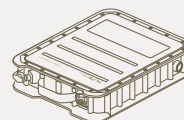

Flitecell Explore

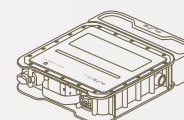

Flitecell Sport
+ spacer

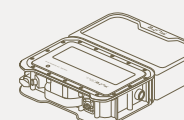

Flitecell Nano
+ spacer

Flitecell Charger

Within the included Flitecell Charger travel bag, you will find either Flitecell Fast Charger or Flitecell Slow Charger, depending on your choice.



Flitecell Charger
travel bag

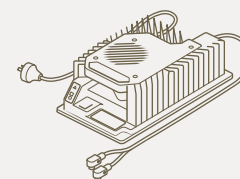

Flitecell Fast
Charger

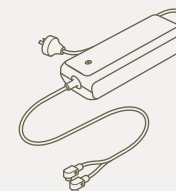

Flitecell Slow
Charger

Flite eFoil

You will receive an eFoil system of your choice in a travel bag.

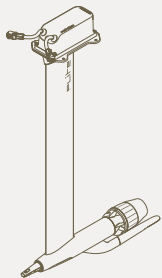

Jet C
80cm / 31.5"
Including Flite Jet 2
Conical wing interface

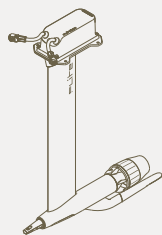

Flitescooter C
65cm / 25.6"
Including Flite Jet 2
Conical wing interface

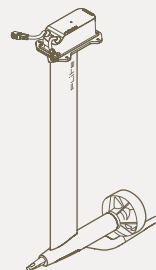

Prop C
80cm / 31.5"
Including Flite Prop with Guard
Including Pro Tail Cover
Conical wing interface

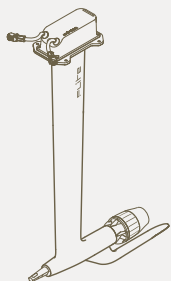

MN Carbon Jet C
82cm / 32"
Including Flite Jet 2
Conical wing interface

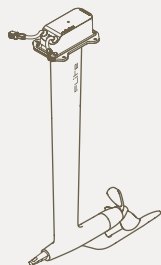

MN Carbon Prop C
82cm / 32"
Including Flite Prop
Conical wing interface

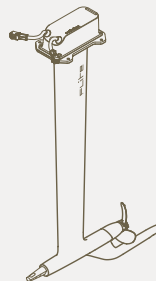

MN Carbon Wave C
82cm / 32", ø46mm
Including MN Wave Folding Prop
Conical wing interface

eFoil packaging

Within the eFoil packaging you will find the following components.

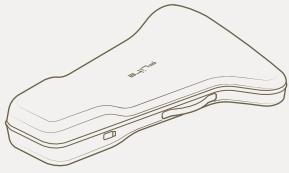

eFoil travel bag

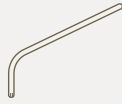

Fastener tool
torx



eFoil Flange fasteners



Fuselage tail fastener
(if required)

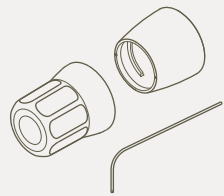

Pro Tail Cover kit (Prop C only)
Pro Tail Cover, Ring Nut Tool,
2.5mm hex key
& 13mm socket

Accessories pouch

Within the accessories pouch you will find the following components and your chosen Flite Controller.

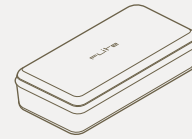

Accessories pouch



Tef-Gel + Brush



Mast Flange Seal



Magnetic Clip



User Guide

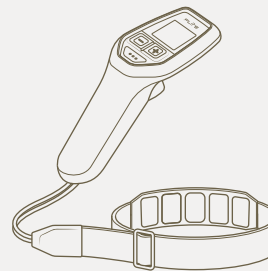

Flite Controller

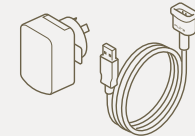

Flite Controller
USB wall charger
and charging cable

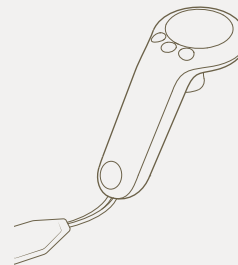

MN Flite Controller

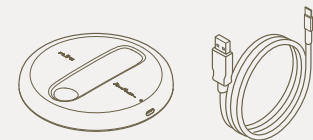

MN Flite Controller
Wireless charger and
charging cable

Flite conical wings

Each wing comes with a cover, fastener tool and associated fasteners.

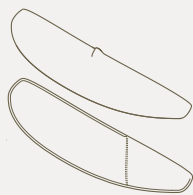

Cruiser Jet 1800 C
2 x M8 x 18mm

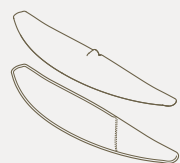

Cruiser Jet 1500 C
2 x M8 x 18mm

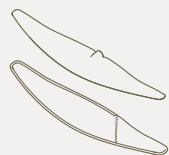

Flow 900 C
Flow 1100 C
2 x M8 x 18mm



MN 1300 C
2 x M8 x 18mm

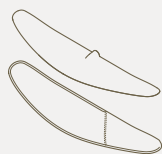

Flow S 1100 C
Flow S 1300 C
2 x M8 x 18mm

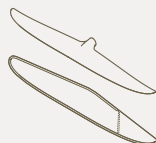

Flux_606
Flux_707_AB
Flux_808_AB
Flux_1010_AB
2 x M8 x 18mm

Rear stabiliser

Each rear stabiliser comes with a cover, shims and associated fasteners.



Stabiliser 500
2 x M6 x 20mm



Stabiliser 300
2 x M6 x 20mm



Stabiliser 245
2 x M6 x 20mm



Flux 125 / 140 / 160 / 195
2 x M6 x 16mm

Getting started

The best way to learn to Fliteboard is to find a Fliteschool in your area. Locate your nearest Fliteschool at fliteboard.com/fliteschool

Watch the Fliteboard video guides in the Flite App. fliteboard.com/app

In order to operate the product correctly, avoiding damage or serious injury, it is essential to read and follow all instructions and warnings in the User Guide prior to assembly, set up or use.

IT IS BEST TO ASSEMBLE YOUR BOARD IN A CLEAN, DRY ENVIRONMENT.

Charging Flite Controller

- 1 Remove Flite Controller from the accessories pouch.
- 2 Remove Flite Controller USB Wall Charger and Charging Cable from the accessories pouch.
- 3 Carefully peel out the rubber cover on the underside of Flite Controller. Attach the magnetic charging plug, ensuring the charging pins are connected.
- 4 Plug in the USB Wall Charger and turn on. When Flite Controller is charging correctly, the screen will show a charging message. Be careful not to disconnect the magnetic charging plug whilst charging. Always check to ensure Flite Controller is at least 50% charged before each use.

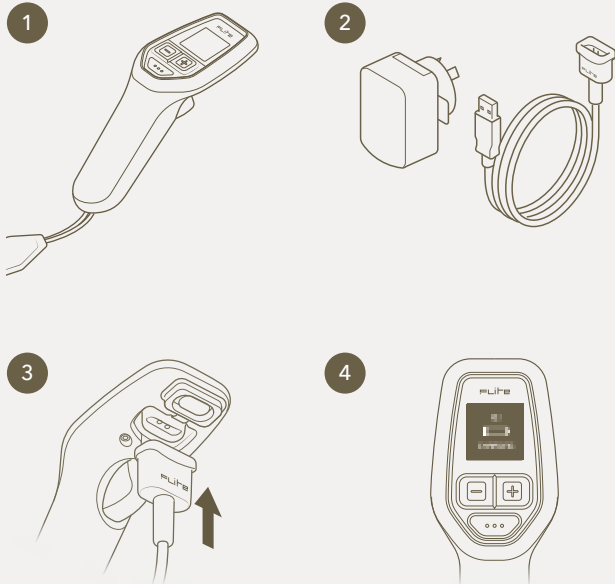

Charging MN Flite Controller

- 1 Remove MN Flite Controller from the accessories pouch in the eFoil bag.
- 2 Remove the MN Flite Controller wireless charger and USB-C cable from the accessories pouch.
- 3 Connect the wireless charger to a USB port (not provided). Place the MN Flite Controller on the wireless charger and check the green LED is flashing. Always check to ensure the MN Flite Controller is at least 50% charged before each use.

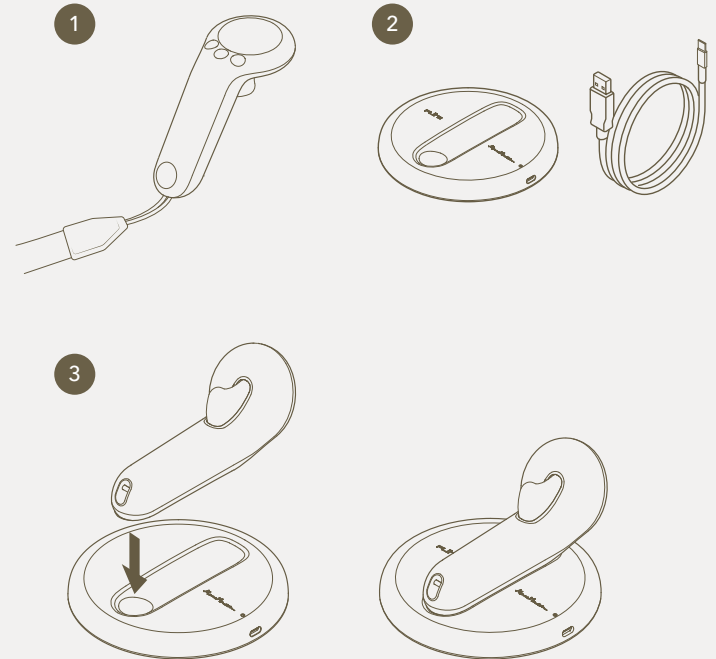

Flitecell charging procedure

DO NOT COVER THE CHARGER OR INTAKE DURING CHARGING. THE CHARGER SHOULD BE PLACED OUT OF THE REACH OF CHILDREN. CHARGE IN AN INDOOR AREA WITH GOOD VENTILATION AND HEAT DISSIPATION.

DO NOT CHARGE IN HUMID, HIGH TEMPERATURE CONDITIONS. DO NOT CHARGE NEAR FLAMMABLES OR EXPLOSIVES. DO NOT DISASSEMBLE THE CHARGER - THERE IS A DANGER OF HIGH VOLTAGE IN THE CHARGER CASE.

DO NOT CHARGE IF FLITECELL IS WET.





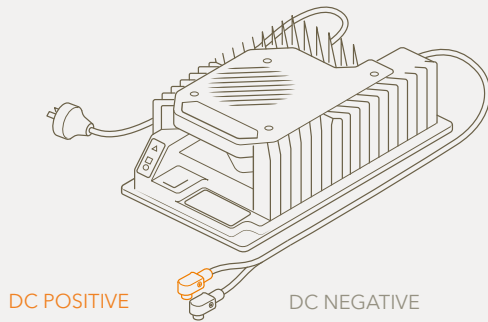

FLITEBOARD DOES NOT BEAR ANY RESPONSIBILITY FOR INCORRECT USE OF THE CHARGER. USERS MUST OPERATE THE CHARGER ACCORDING TO THE USER GUIDE.

ALWAYS KEEP THE RED TERMINAL CAPS ON THE FLITECELL WHEN NOT CONNECTED TO THE BOARD/CHARGER.

Flitecell Fast Charger



Flitecell Indicator Guide

	Power on	
	Flashing green	Charging
	Solid red See charger manual	Charger fault
	Flashing amber See charger manual	External error
	Flashing green	USB port active
	Solid green	Safe to remove USB flash drive

Charging Flitecell

- 1 Remove Flitecell from its travel bag.
- 2 Place Flitecell in a cool dry location away from flammable or hot items. Safe charging temperatures are 0 - 40°C and optimal charging temperatures are 10 - 30°C.
- 3 Connect Flitecell charger plugs to Flitecell terminals ensuring to connect the orange (positive) connector to the orange terminal first and the black (negative) connector to the black terminal.
- 4 Check that connections have been made correctly. Plug the charger in the wall socket. Place the supplied magnet on the Flitecell for 5 - 10 seconds, as shown by arrow, to activate charging. If the magnet has been misplaced, you can use the base of Flite Controller to initiate charging.
- 5 The charger will automatically turn off when the charging process is complete.





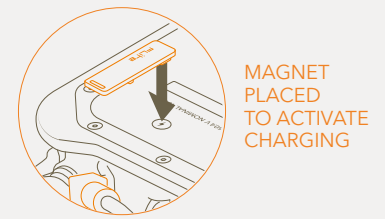
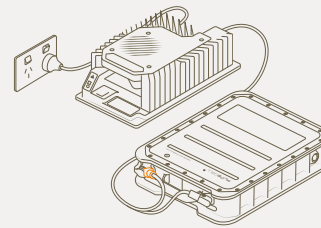

FLITECELL IS A POWERFUL BATTERY CONTAINING A SIGNIFICANT AMOUNT OF ENERGY. CHARGING A DAMAGED FLITECELL CAN RESULT IN A FIRE OR EXPLOSION. ALWAYS INSPECT THE FLITECELL BEFORE CHARGING. CHARGE THE FLITECELL UNDER SUPERVISION, IN A SAFE LOCATION, AWAY FROM DIRECT SUNLIGHT, MOISTURE AND AWAY FROM FLAMMABLE OBJECTS AND SURFACES.

THE BATTERY MANAGEMENT SYSTEM (BMS) BALANCES AND OPTIMISES FLITECELL DURING EACH CHARGE CYCLE.

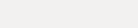
IT IS RECOMMENDED TO DISCONNECT THE FLITECELL AFTER A FULL CHARGING CYCLE.

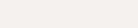

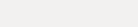
Flitecell light

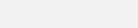
Flitecell light	Light meaning
	Capacity 0% - 10%
	Capacity 10% - 20%
	Capacity is 20% - 35%
	Capacity 20% - 35% + charging
	Capacity 35% - 65%
	Capacity 35% - 65% + charging
	Capacity 65% - 100%
	Capacity 65% - 100% + charging

Inflating AIR

- 1 Twist the valve cap anti-clockwise to remove.
- 2 To inflate, push the central valve down.
- 3 Twist anti-clockwise to release.
- 4 The valve will pop up. This ensures the bladder will not deflate when you remove the hose after inflation.

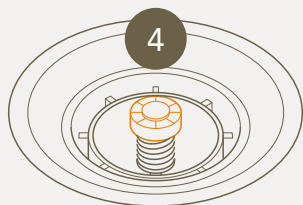
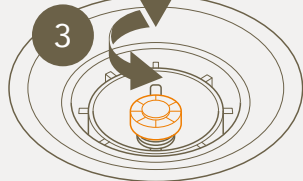
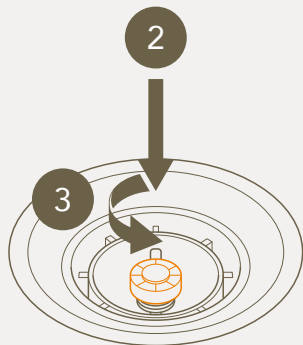
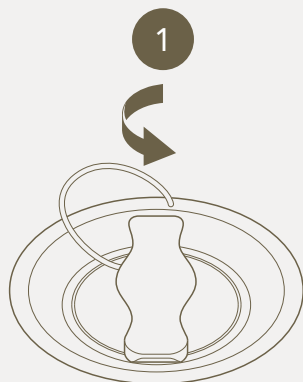

- 5 Connect pump hose to valve and inflate bladder to 15 - 16 PSI.
THIS IS IMPORTANT FOR OPTIMUM PERFORMANCE AND SAFETY.

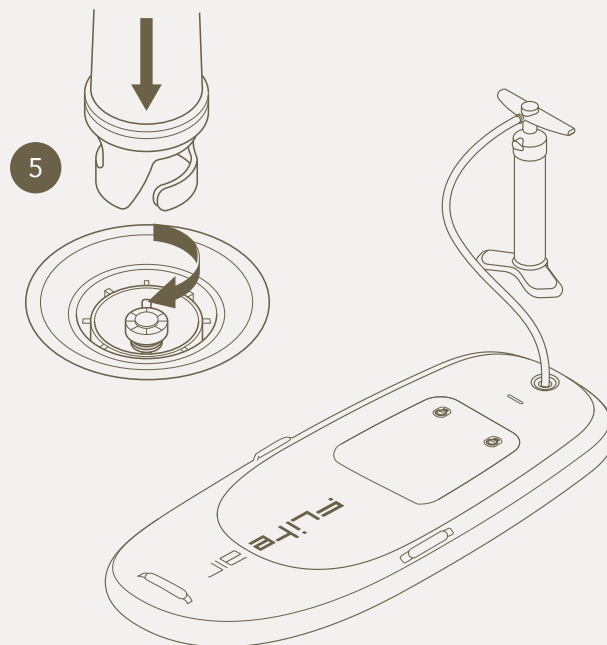

- 6 Once inflated to 15 - 16 PSI, twist the pump hose anti-clockwise to remove and re-fit the valve cover cap. When disconnecting the pump hose, no air should escape from the valve. If the bladder deflates you must release the central valve (see step 2) and re-inflate. AIR is now inflated.

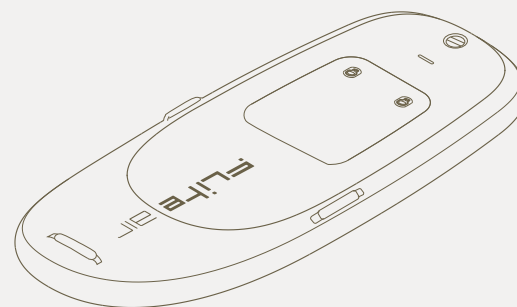

Connect the eFoil to Fliteboard

- 1 Place the Fliteboard upside down on a clear surface. Locate the Flitebox cavity on the bottom of the board and ensure the 4 retaining screws are removed.
- 2 Check to ensure the orange o-ring is inserted, properly seated in the Flitebox cavity o-ring groove, clean and free of sand, grit or water.
- 3 Carefully lift the eFoil from its bag and place the Flitebox into the cavity. While doing this ensure the power cables feed through into the Fliteboard cavity.
- 4 Ensure the Flitebox is properly seated in the cavity and flush with the board surface.
- 5 Add a thin layer of Tef-Gel to the 4 x 20mm stainless steel fasteners. Tighten them in a cross pattern, first using your fingers to ensure the threads are properly engaged, and then using the supplied torx key. Medium force (a torque of 6 Nm) needs to be applied when using the long arm of the key to ensure the fasteners are tight.
- 6 When properly tightened, the eFoil should be secured and the o-ring compressed. Failure to properly tighten the fasteners or fit the o-ring will result in a board leak.
- 7 Be careful not to over-tighten the fasteners as this could result in stripped threads or damaged fasteners.

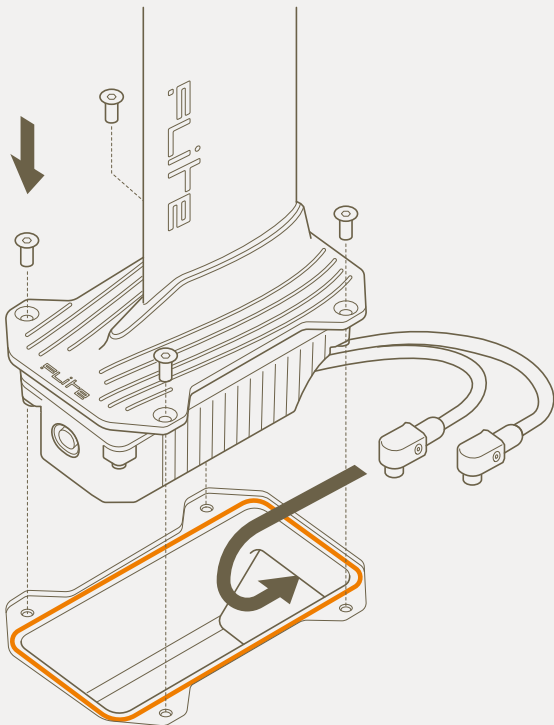

Connect the wing

- 1 Remove the front wing from its wing cover.
- 2 Place the wing in position as shown.
- 3 ALWAYS add Tef-Gel to the fasteners before inserting them.
- 4 Tighten the fasteners with the supplied torx key, ensuring the fasteners are tight enough that the wing cannot move or wobble significantly during use. Use a torque of 16Nm for the M8 fasteners.

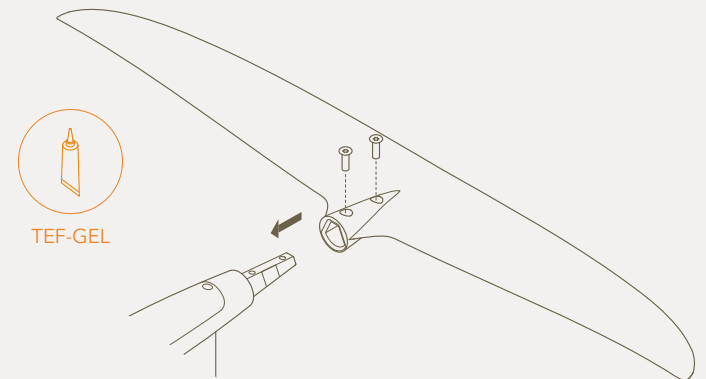

Connect the fuselage tail

- 1 Place the board upside down with the eFoil connected. Take the fuselage tail from the travel bag, add a light cover of Tef-Gel to the tail connection and install the tail into the fuselage.
- 2 Add a thin layer of Tef-Gel from the tube supplied to the thread of the supplied 16mm fastener. Carefully tighten using the supplied torx key, ensuring the fastener is tight enough that the tail cannot move or wobble significantly during use. Use a torque of 6Nm to tighten the fastener. You may need to push the tail (compresses the o-ring) for the screw to find the thread. Misalignment may cause damage to the thread.

MN CARBON EFOILS DO NOT HAVE A SEPARATE FUSELAGE TAIL.

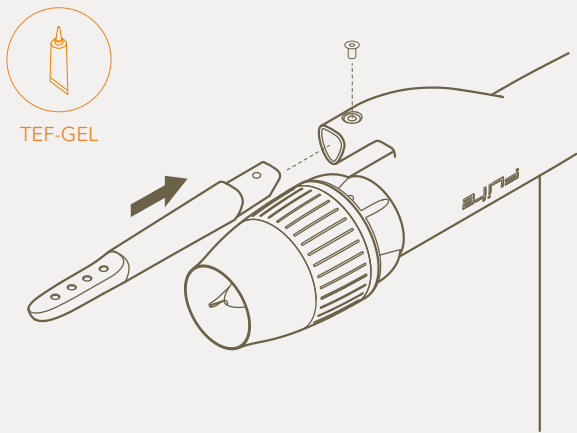

Connect the stabiliser wing

- 1 Remove the stabiliser wing from its wing cover.
- 2 Select a stabiliser wing shim and fit between the stabiliser wing and tail interface.
- 3 To ensure correct mounting, direction and placement, the wing when installed correctly should have the rounded, curved leading edge facing the front wing.

ALWAYS ADD TEF-GEL TO THE STAINLESS STEEL FASTENERS - FAILURE TO DO SO MAY RESULT IN CORROSION AND DAMAGE TO YOUR EFOIL. IF LEAVING WINGS ATTACHED FOR EXTENDED PERIODS, ENSURE THAT YOU LOOSEN FASTENERS AND RE-APPLY TEF-GEL EVERY FEW WEEKS. FAILURE TO DO SO MAY RESULT IN CORROSION AND DAMAGE TO YOUR EFOIL FASTENER INSERTS.

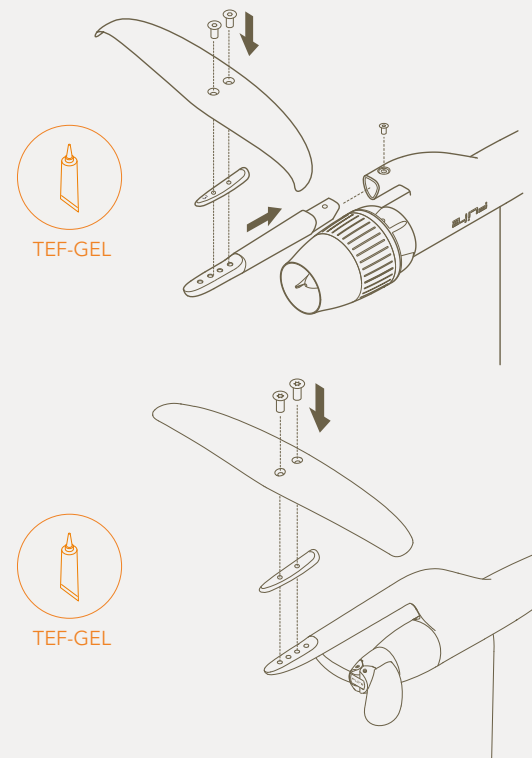

Shim **1.0** suits most riders.

Move forward or back on the board to find a balanced and comfortable standing position when foiling.

Shim 1.0 to 3.0 = More lift
Standing position further forward

Shim 0 to 1.0 = Less lift
Standing position further back

Pro Tail Cover installation

The Prop Guard can be removed from the Prop C eFoil and replaced with the Pro Tail Cover. Pro Tail Cover is for advanced riders only, who use it at their own risk, instead of the Prop Guard .

- 1 Remove the propeller nut with the tool provided and remove the Prop.

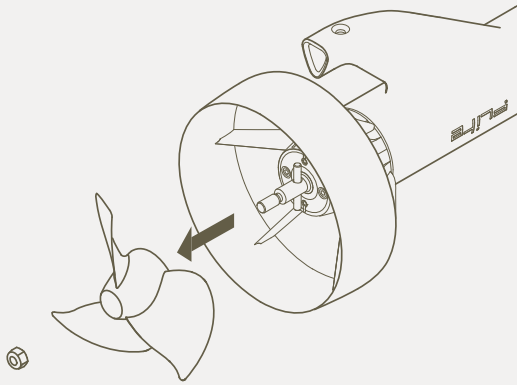

- 2 Using a 2.5mm hex key, loosen the 2 x M4 grub screws on the End Cap. Do not unscrew all the way out. Do not loosen the oil port screws.

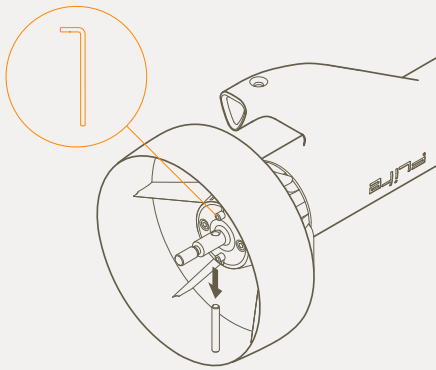

- 3 Slide the ring nut tool over the ring nut. Rotate anti-clockwise to loosen.

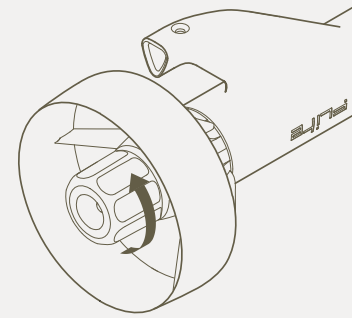

- 4 To remove the ring nut, pull it towards you. Remove the Prop Guard by rotating anti-clockwise and pulling at the same time.

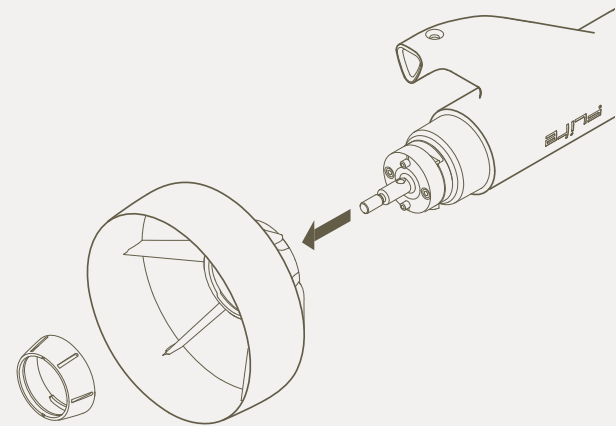

- 5 Slide the Pro Tail Cover onto the End Cap and rotate clockwise until the locating notches line up.

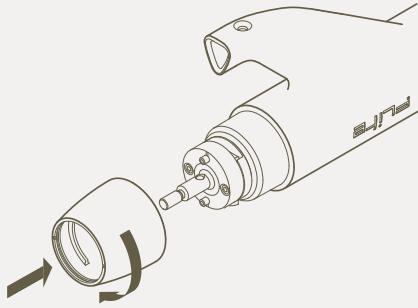

- 6 Using a 2.5mm hex key, tighten the two M4 grub to 3Nm. Re-install the Prop with the propeller nut using the tool provided, rotating clockwise.

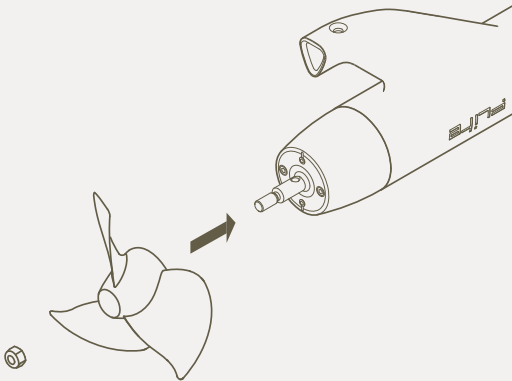

Dual Drive for Prop C

Fliteboard eFoils with the Dual Drive system allow you to swap between the Flite Propeller module with a Pro Tail Cover and Flite Jet 1 quickly and without using tools. Dual Drive is only relevant for the Prop C eFoil system. Flite Jet 2 is not Dual Drive compatible.

We recommend connecting the eFoil to the Fliteboard first for safer and easier installation.

- 1 Connect the eFoil to the Fliteboard.
- 2 The Dual Drive system uses a reverse thread. Remove the Flite Propeller module by carefully gripping the Pro Tail Cover and rotating **CLOCKWISE**.
- 3 Check the fuselage thread is clean and free of sand, grit or water.
- 4 Check the Flite Jet thread is clean and free of sand, grit or water. Wipe clean if necessary.
- 5 Apply a small amount of Tef-Gel to the thread of the Flite Jet.
- 6 Install the Flite Jet by rotating **ANTI-CLOCKWISE** until there is no gap between the jet and fuselage. This should be just finger tight.
- 7 If there is any resistance during installation, remove the Flite Jet completely to check for sand and grit. Try again without using excessive force. Rotate until the gap is closed.
- 8 Pair Flite Controller and hold the Mode button (bottom) until the settings screen is displayed. Follow the on-screen instructions to select Jet.
- 9 Check that 'Jet' is displayed on the Speed / Gear screen. Jet mode adjusts the virtual gears for a better experience when Fliteboarding with the Flite Jet.

Add a thin layer of Tef-Gel periodically to the threads of the Flite Propeller module and Flite Jet.

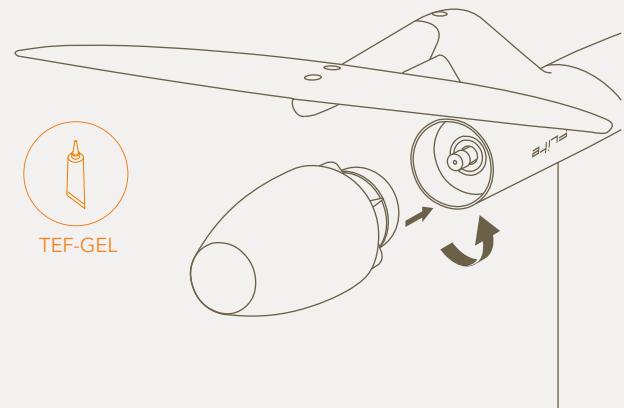

RACE impeller installation

The Flite x Mercury Racing RACE impeller is an upgraded impeller designed for the Flite Jet 2 propulsion system, its purpose is to increase thrust, acceleration, and top speed. RACE impeller will come in a separate box. Here's how to safely install it in just a few simple steps, using the tools you already have on hand.

1. Rotate the nozzle clockwise to remove it from the Jet assembly.

2. Use a cloth or towel to hold the impeller firmly. This protects your hand and provides grip for the next step.

3. With a 13mm socket tool, loosen and remove the impeller nut.

4. Gently pull the impeller off the shaft. Take care not to damage the internal components.

5. Remove the pin from the shaft before fitting the RACE impeller.

Pro tip: Keep the impeller pin horizontal before removing. This will ensure the impeller pin does not fall out upon reinstallation.

6. Place the new impeller pin into position. Slide the RACE impeller onto the shaft, then reassemble in reverse order. Make sure all components are secure before your next ride.

Pro tip: After installation, double-check that the impeller spins freely and that all fittings are tight.

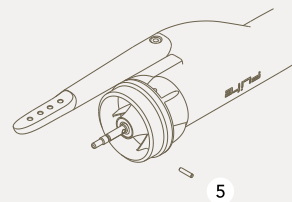
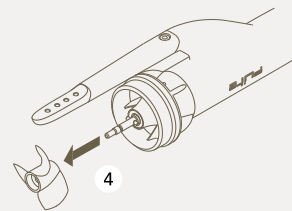
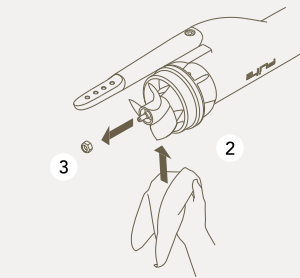
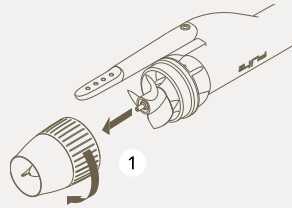

RACE handles installation

Handles will come in your board box and can be installed if you would like them.

On the deck of the RACE board, you will find 4 pre-drilled pilot holes where the handle screws are to be positioned.

Tighten the 4 x handle screws into the pre-drilled screw holes in the nylon block of the board using a Phillips head screwdriver. Force is needed. Ensure you do not burr the screw heads.

Tighten the screws until the heads of the screw sit 8mm off the deck of the board.

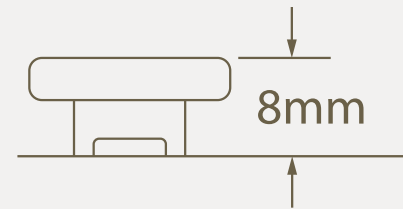

Now place the handles over the screws. Push down to ensure a snug fit, then rotate the screws 90 degrees using the designated handle tool to lock the handle into place. Repeat this step for the remaining handle.

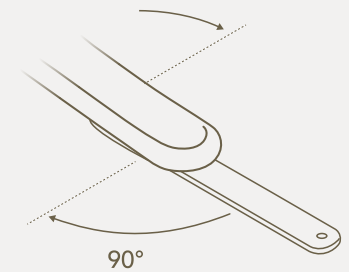
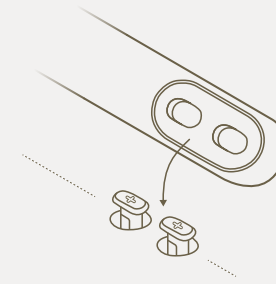

Connect Flitecell to Fliteboard

With the eFoil, fuselage tail and wings attached, it's time to carefully turn your board over so it stands on BOTH the front wing and nose of the board.

- 1 Twist the lid latches and open the board lid.



DO NOT OPEN LID WHILST IN THE WATER UNDER ANY CIRCUMSTANCES.

- 2 Take Flitecell by the handle and carefully lower it into the board cavity, ensuring to move cables out of the way first. The warning label should be facing up.
- 3 If a Flitecell spacer is needed, place it in the board cavity first.

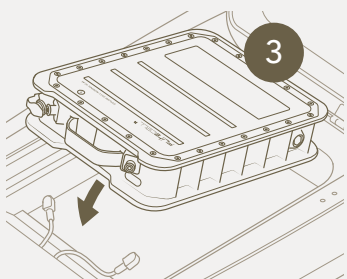

BE CAREFUL NOT TO DAMAGE THE BOARD SEAL WHEN FITTING FLITECELL. ANY NICKS, CUTS OR DAMAGE TO THE SEAL MAY RESULT IN LEAKS.

BE CAREFUL NOT TO RECONNECT FLITECELL POWER CABLES WITHIN 10 SECONDS OF DISCONNECTION TO AVOID A POSSIBLE ARC.

- 4 Connect the orange power cable to the orange power in Flitecell. You will feel a secure click when properly engaged. Note - Depress the button on the side of the connector when removing the connector.
- 5 Connect the black power cable to the black power in Flitecell.

Flitecell is now connected.

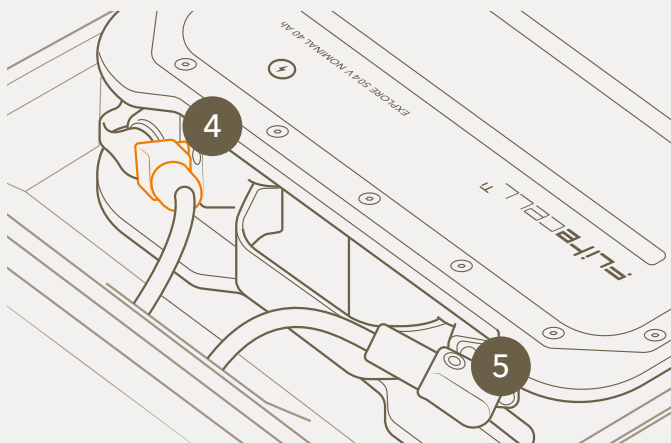

Turning on Flitecell

- 1 Make certain nothing is caught in the seal. Carefully close the lid.
- 2 Twist and lock the two lid latches.
- 3 A few seconds after the lid is shut in position, you will hear a **'beep beep beep'** which signifies that the Flitecell and board have automatically turned on.
- 4 If the external board light is not active, open the lid and ensure the power cables are properly connected, and there are lights on the Flitecell indicating it is switched on.
- 5 Flitecell will automatically turn off 10 seconds after the lid is opened.

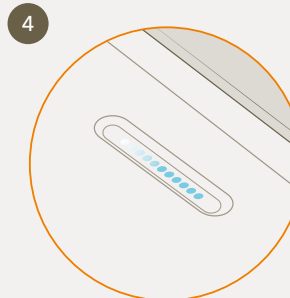
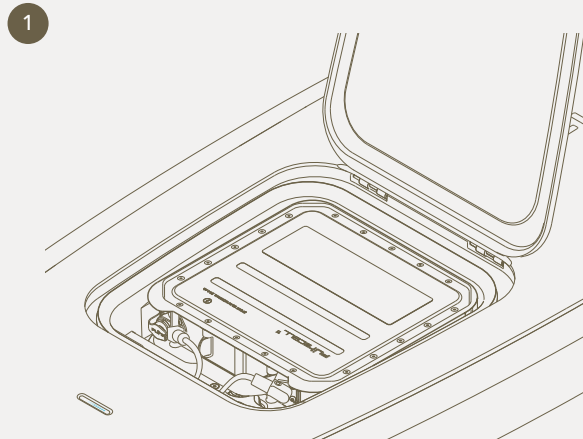

SEE PAGE 41 FOR PAIRING FLITE CONTROLLER

THE SEAL IS A CRITICAL COMPONENT. IF DAMAGED CONTACT YOUR FLITE SERVICE DEALER FOR A REPLACEMENT PART. NEVER RIDE THE BOARD WITH A DAMAGED SEAL.

THE FLITECELL AND CABLES ARE WATER RESISTANT; HOWEVER, ALWAYS KEEP FLITECELL, CABLES AND BOARD CAVITY DRY. WATER, ESPECIALLY SALT WATER, CAN ACCELERATE AGEING AND CORROSION. IF YOUR BOARD LEAKS, CHECK SEALS, AND CLEAN COMPONENTS CAREFULLY.

Download Flite App and update

Before use, this product must be activated using the Flite App.
fliteboard.com/app

Flite App is available to download in the Apple App Store™ and Google Play Store™. We recommend using Flite App to ensure your eFoil and Flite Controller always have the latest software to deliver the best performance.

In addition to enhancing your experience on the water, Flite App connects you to a global community of Fliteboard riders. Share your sessions, compete and discover new places to ride.



Download
Flite App

fliteboard.com/app

Connecting Flite App to Fliteboard

- 1 Turn off Flite Controller.
- 2 Ensure Fliteboard has power and the lid is closed.
- 3 Select **'Fliteboard'** from the **'Devices'** menu. When connected, the board Flitebox LED will turn purple. When performing some updates it will display green.
- 4 You will now be able to see the software version of the Fliteboard.
- 5 Once connected you can perform updates and sync session rides.

ENSURE FLITE CONTROLLER IS TURNED OFF AS THE APP CAN ONLY CONNECT TO ONE DEVICE AT A TIME.

WHEN NEW SOFTWARE UPDATES ARE AVAILABLE, YOU'LL SEE AN ORANGE UPDATE ICON.

WHEN CONNECTING TO THE APP, IT'S IMPORTANT TO FIRST CONNECT TO YOUR EFOIL OR YOUR FLITECELL WILL NOT BE VISIBLE OR CONNECTABLE.

BEFORE YOU UPDATE SOFTWARE MAKE SURE THE PHONE, FLITECELL AND FLITE CONTROLLER HAVE AT LEAST 20% CHARGE.

KEEP THE PHONE CLOSE AND IN LINE OF SIGHT WITH A STRONG WIFI/ CELLULAR NETWORK. DON'T USE THE PHONE FOR ANYTHING ELSE SUCH AS CALLS, TEXTS, OR OTHER APPS.

MAKE SURE THE FLITEBOARD LID REMAINS CLOSED DURING THE UPDATE PROCESS.

Capturing sessions

- 1 Fliteboard will automatically capture sessions to its onboard computer.
- 2 Connect to the Fliteboard and then tap **'Sync'** to view and download any new sessions.
- 3 Clicking a ride in the **'Sessions'** list will then take you to the ride detail screen. Here you can play back your ride in various speeds, over an aerial map.

Flite Controller overview

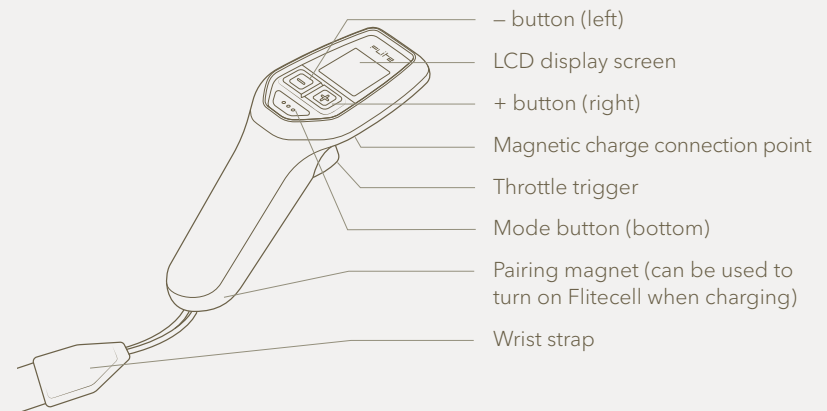

MN Flite Controller overview

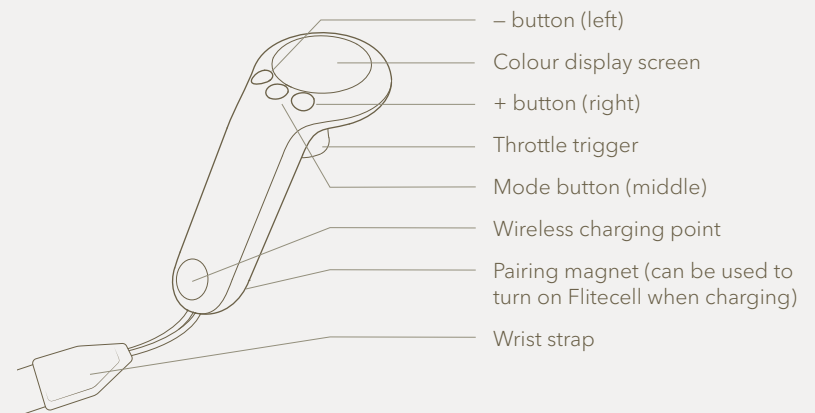

Turn on Flite Controller

- 1 Turn on Flite Controller by holding down the + button (right) AND Mode button (bottom) together for 3 seconds.
- 2 After a 3 second press of both buttons, the Flite logo will appear with the software version number, and the Controller will move to the home screen with lock icon.

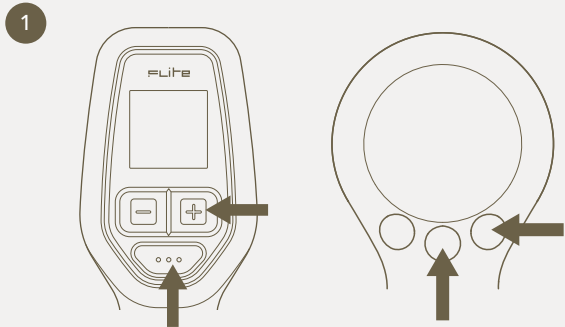

Connecting Flite App to Flite Controller

- 1 Open the lid. Fliteboard will turn off after a few seconds.
- 2 Turn on Flite Controller by holding down the + button (right) AND Mode button (bottom) together for 3 seconds.
- 3 Ensure Flite Controller has power and is within range of the phone.
- 4 Select **'Flite Controller'** from the **'Devices'** list. When selected and connected, the current state of charge will be displayed.
- 5 You will now be able to see the software version of Flite Controller, perform any updates and change settings (e.g. kilometres, knots and miles per hour).

WHEN NEW SOFTWARE UPDATES ARE AVAILABLE, YOU'LL SEE AN ORANGE UPDATE ICON. WHEN UPDATING, DON'T USE THE PHONE FOR ANYTHING ELSE SUCH AS CALLS, TEXTS OR OTHER APPS.

Flite Controller pairing procedure

- 1 Ensure Flitebox power cables are connected to Flitecell. Close the lid and wait for the audible beep indicating the board is switched on.
- 2 Open the Fliteboard lid and place the base of Flite Controller on the pairing target of the Flitebox (between the Flitecell cables). Note - With the lid open, the system will shut down after 20 seconds.
- 3 Once the LED lights change to scrolling orange, remove Flite Controller from the pairing target and close the lid.
- 4 Set the controller into pairing mode by holding the + button (right) for 7 seconds until the words **'PRESS MODE TO COMMENCE PAIRING'** appear. Then press Mode button (bottom) to confirm. The words **'LOOKING FOR NEW PAIR'** will appear.
- 5 Once paired successfully, the LEDs will change to a light blue colour.
- 6 Fasten the latches once paired successfully.

Troubleshooting - If the lights are not solid blue, or the battery icon on your Flite Controller is crossed out, this indicates that the Flitecell has not paired, and the process needs to be repeated from Step 1.

The Magnetic Clip can be used to keep Flitecell activated longer. Remove once paired.

DO NOT HOLD FLITE CONTROLLER IN THE PAIRING POSITION FOR MORE THAN 30 SECONDS. HOLDING FLITE CONTROLLER IN THIS POSITION WILL PUT THE BOARD INTO SOFTWARE UPDATE.

Flitebox light	Flite Controller meaning
Light blue solid	Ready to ride
Red flashing	Alert (high temp, tilt, overcurrent, system error)
Blue flashing	Armed
Blue chasing	Motor running
Orange flashing	Disconnected Flitecell / Controller
Orange chasing	Searching for new pair Flitecell / Controller
Purple solid	Flite App connected
Purple chasing	Flite App data transfer

Flite Controller

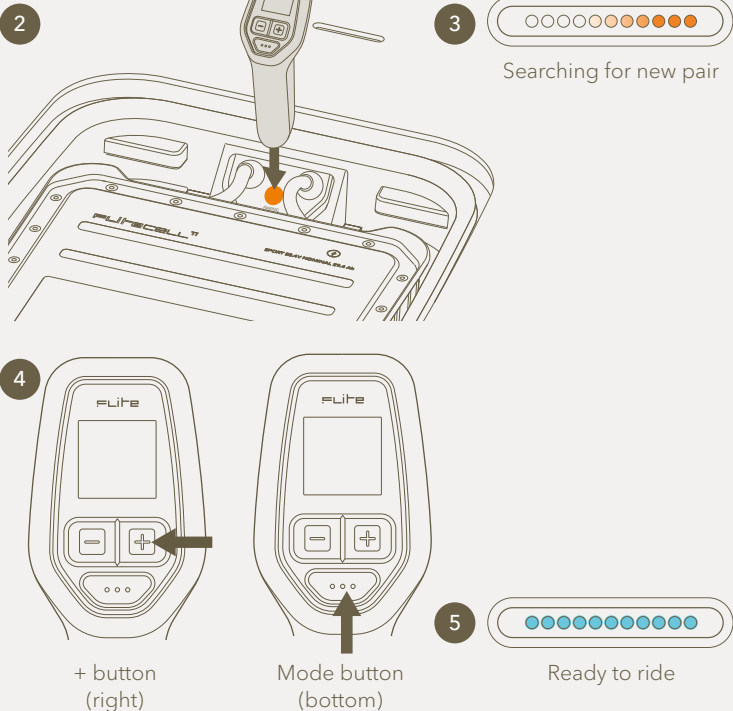

MN Flite Controller

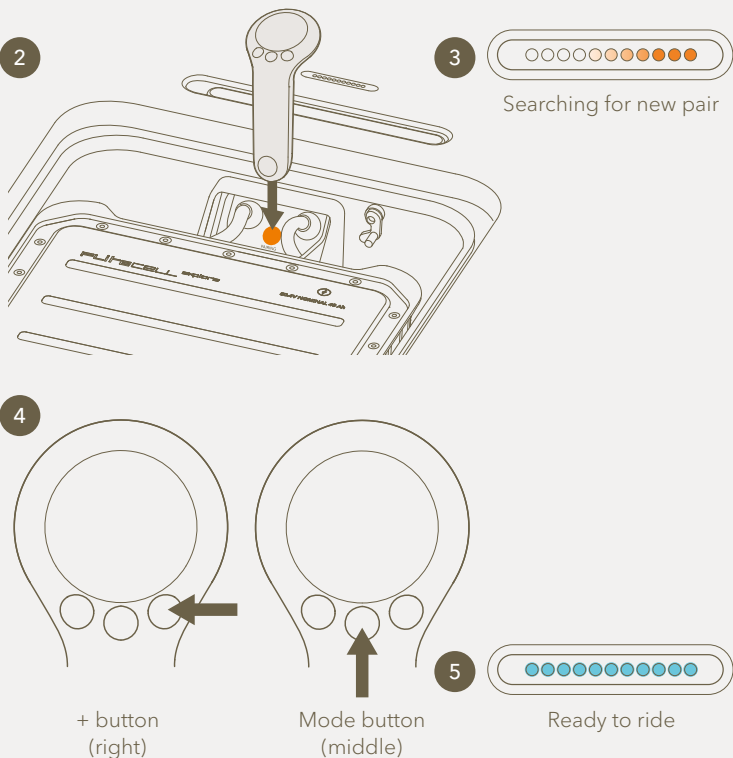

Ride settings

Ride settings can be updated using Flite App or Flite Controller.

To change settings using Flite Controller, first connect to the Fliteboard then hold Mode button (bottom) until the settings screen is displayed.

To change settings using Flite App, connect Flite Controller to Flite App. You will be able to edit speed and distance units.

PLEASE BE AWARE THAT SPEED READOUT REQUIRES A GPS CONNECTION. IF YOU ARE RIDING WITH POOR GPS SIGNAL YOU MAY NOT BE ABLE TO SEE YOUR CURRENT SPEED.



Flite Controller screens

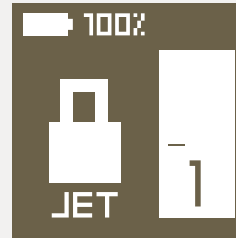

Motor locked

Ready to arm.
Flitecell 100% charged
Gear set to 1
Jet propulsion selected

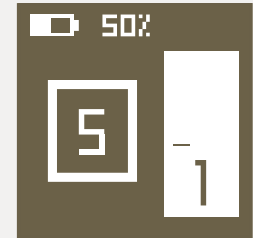

Motor armed

Motor unlocked with 5 seconds
to squeeze the throttle trigger.
Flitecell charge 50%



Current Speed / Gear

Speed 1.3 km/h
Gear 1



Distance

Travelled 6.4 kms
Remaining 24.7 kms
Current Speed 23.6 km/h



Time

Elapsed 60 mins
Remaining 12 mins
Current speed 23.6 km/h



Speed

Maximum 35.1 km/h
Average 13.2 km/h
Current speed 23.6 km/h

Flite Controller screens

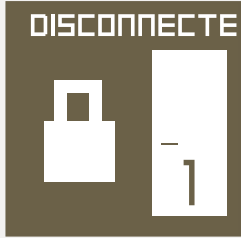

Disconnected (scrolling)

Flite Controller is not connected or board is under water. Check Fliteboard is turned on and showing LEDs.

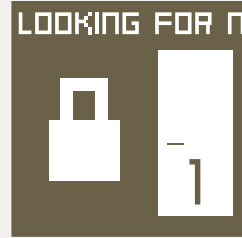

Looking for new pair (scrolling)

Flite Controller is looking for a new pair.



Charge remaining

Flitecell 98%
Flite Controller 66%

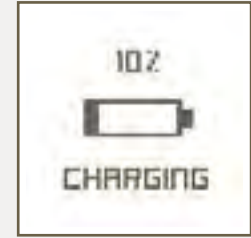

Flite Controller charging

Flite Controller currently at 10% state of charge.

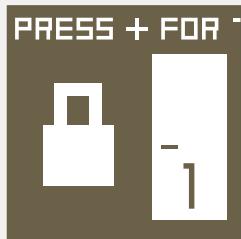

Pairing required

Flite Controller is not paired. Hold + button (right) for 7 seconds until Flite Controller displays LOOKING FOR NEW PAIR.

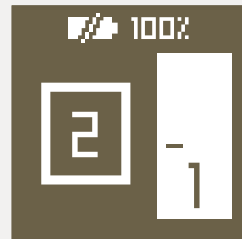

Battery not paired

Repeat pairing process (see page 41).



50% Flitecell warning

Flitecell has 50% (or less) remaining charge.



Fliteboard tilted

Fliteboard is disabled due to the tilt angle.

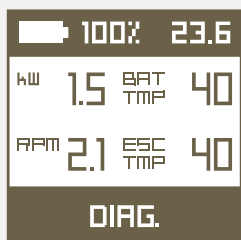

Diagnostics

Power 1.5 kW
RPM x 1000 = 2,100
ESC Temp 40°C
Flitecell Temp 40°C
Flitecell Charge 100%
Current Speed 23.6 km/h



Efficiency

60 Wh/km
Flitecell charge 100%
Current speed 23.6 km/h

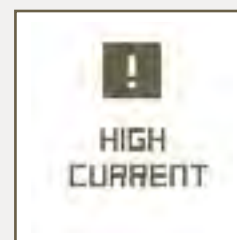

High Current

Motor Cool Down mode will be activated if power isn't reduced.

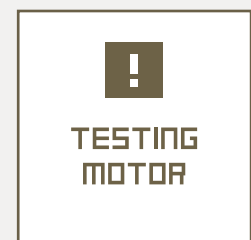

Testing Motor

To avoid accidental injury, this feature prevents the motor from being turned on fully and any overheating of seals, when the board is on land.

MN Flite Controller screens

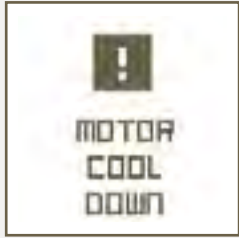

Motor Cool Down

The motor needs to cool down. Fliteboard is limited to low gears for 1 minute to allow motor to cool.

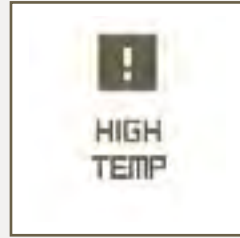

High Temp

Flitecell is too hot. Ride using low power to allow Flitecell to cool, otherwise Flitecell may shut down.

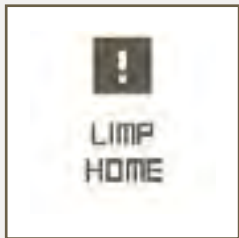

Flitecell charge critical

Flitecell charge very low, immediately return to shore. Fliteboard is limited to low gears only to conserve charge.



Flite Controller low charge

Flite Controller requires charge. Ensure Flite Controller is charged above 50% each ride.



Motor locked

Ready to arm.
Flitecell 75% charged
Gear set to 1
Prop propulsion Power 0 kW



Motor armed

Motor unlocked with 5 seconds to squeeze the throttle trigger.
Flitecell 75% charged



Current Speed / Gear

Speed 1.3 km/h
Throttle trigger 80%
Power 3 kW

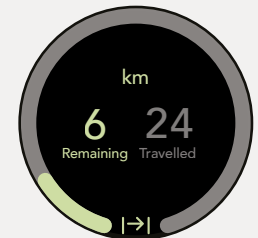

Distance

Travelled 24 km
Remaining 6 km



Time

Elapsed 60 min
Remaining 12 min
Time 12:25

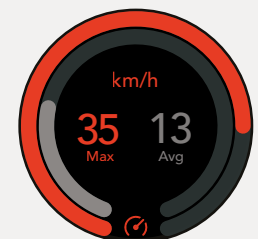

Speed

Maximum 35 km/h
Average 13 km/h

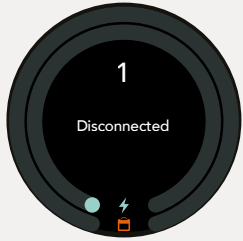

Disconnected

Flite Controller is not connected or board is under water. Check Fliteboard is turned on and showing LEDs.



Looking for new pair

Flite Controller is looking for a new pair.



Wave riding

Current wave 1:02 seconds and 112 meters
Gear 7



Wave summary

Best wave 2:51 seconds and 1203 meters
Total 17 waves and 5.8 km unpowered

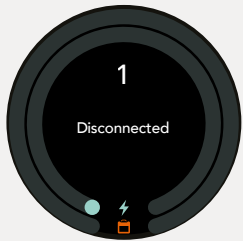

Pairing required

Flite Controller may not be paired. Hold + button (right) for 7 seconds until Flite Controller displays LOOKING FOR NEW PAIR.



Battery not paired

Repeat pairing process (see page 41).

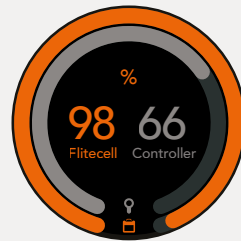

Charge remaining

Flitecell 98%
Flite Controller 66%

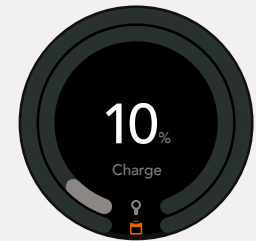

Flite Controller charging

Flite Controller charging at 10% state of charge.

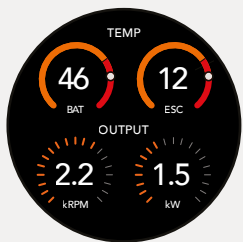

Diagnostics

Flitecell kilowatts 1.5
RPM x 1000 = 2,200
ESC Temp 12°C
Flitecell Temp 46°C



Efficiency

64 Wh/km
23.2 km/h

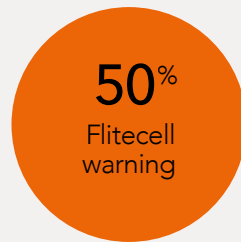

50% Flitecell warning

Flitecell has 50% (or less) remaining charge.



Fliteboard tilted

Fliteboard is disabled due to the tilt angle.



High
current

High current

Motor Cool Down mode will be activated if power isn't reduced.



Testing
motor

Testing motor

To avoid accidental injury, this feature prevents the motor from being turned on fully and any overheating of seals, when the board is on land.



Motor cool
down

Motor cool down

The motor needs to cool down. Fliteboard is limited to low gears for 1 minute to allow motor to cool.



Flitecell
temp high

Flitecell temp high

Flitecell is too hot. Ride using low power to allow Flitecell to cool, otherwise Flitecell may shut down.



Limp home

Flitecell charge critical

Flitecell charge very low, immediately return to shore. Fliteboard is limited to low gears only to conserve charge.



Controller
battery low

Flite Controller low charge

Flite Controller requires charge. Ensure Flite Controller is charged above 75% each ride.

Get Fliteboarding

Fliteboard recommends that first time riders have at least one lesson with a certified Fliteschool. To find your nearest Fliteschool visit fliteboard.com/locations

Fliteboard safety aids

We have implemented the following features to help you have a safe and enjoyable experience on Fliteboard:

- Draw Fly Zones on Flite App to help avoid shallow water and other obstacles
- Speed limiter which can be changed in Flite App or Flite Controller

Select a suitable riding location

A location with deep enough water is essential. The wings and eFoil should never make contact with anything below the surface, including a sand bottom. Be aware of tide times, as well as submerged items such as branches, coral, boat chains and fishing lines. If you are unsure about the local area ask someone who knows the waterway for advice. Be aware the board can be submerged with rider weight, increasing the required clearance.

Choose a location away from swimmers and other water users and ensure local laws allow motorised craft to be used in the area.

Learning to Fliteboard in very smooth water without waves or strong currents is SIGNIFICANTLY easier and safer than learning in choppy water. Your first Fliteboard experience will be challenging (but rewarding) so choose a location and weather conditions that allow for the easiest possible learning experience.

Ride time and range are dependent upon:

- Rider weight
- Average speed
- Wing choice
- Water / wind conditions

ENSURING SAFE WATER DEPTH IS EXTREMELY IMPORTANT BEFORE RIDING. SELECT A LOCATION THAT HAS A MINIMUM DEPTH OF AT LEAST 1.5 METRES.

ALWAYS MONITOR FLITECELL LEVELS WHILE RIDING AND TAKE CARE NOT TO DEplete THE FLITECELL BEFORE RETURNING TO YOUR POINT OF ORIGIN.

NEVER RIDE FLITEBOARD FURTHER FROM SHORE THAN YOU ARE PREPARED TO SWIM BACK.

Arming the motor

Fliteboard uses a safety lock to guarantee that riders cannot accidentally spin the motor by bumping the throttle trigger unintentionally. On land the eFoil will be in motor test and will not fully spin. This is by design.

Riders must arm (unlock) the motor to Fliteboard.

- 1 To arm the motor, pull the throttle trigger all the way in on Flite Controller and then release it completely.
- 2 Press and then release the – button (left).
- 3 Pull the throttle trigger within the 5 second countdown window to activate the Flite Propeller or Flite Jet. Always verify the eFoil is clear and in a safe location before activating the motor.

IMPORTANT - NEVER RUN THE MOTOR OUT OF WATER FOR MORE THAN 3 SECONDS, AS DOING SO CAN OVERHEAT AND DAMAGE THE SHAFT AND SEALS.

ALWAYS ENSURE FLITE CONTROLLER LANYARD IS ADJUSTED AND SECURELY ATTACHED TO YOUR WRIST BEFORE FLITEBOARDING.

ALWAYS TEST THE TRIGGER RESPONSIVENESS AT THE START OF YOUR FLITEBOARDING SESSION TO ENSURE IT IS FUNCTIONING CORRECTLY.

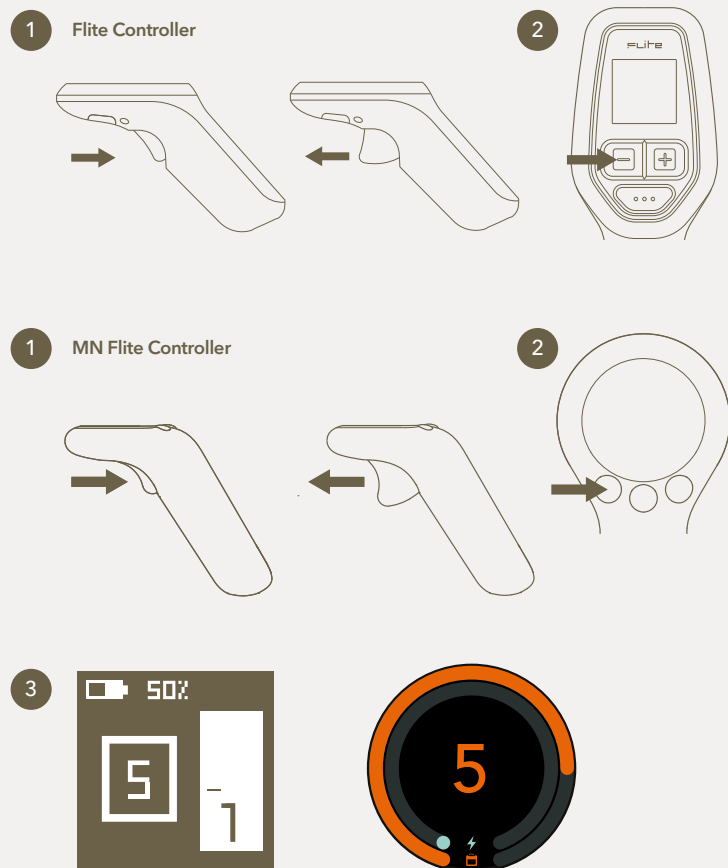

Engage the motor and get moving

- 1 Climb onto the board, taking care not to kick the hydrofoil wings or mast.
- 2 Lie on the board, positioned so that you can touch the front of the Fliteboard with your hand (or the front handle if using AIR).
- 3 Verify Flite Controller is set so you can see gear 1 displayed on the lock screen. This is your starting gear setting once armed (it can be changed later if you are an advanced rider).
- 4 Arm the motor and squeeze the gear 1 throttle trigger. The board should start to move. You should be on power level 1 (a low gear setting).
- 5 Practice riding lying on the board and changing speed using the – button (left) and + button (right) between gear 1 and gear 3. Be sure to keep enough weight on the front of the board to keep the nose of the board down and parallel to the water.

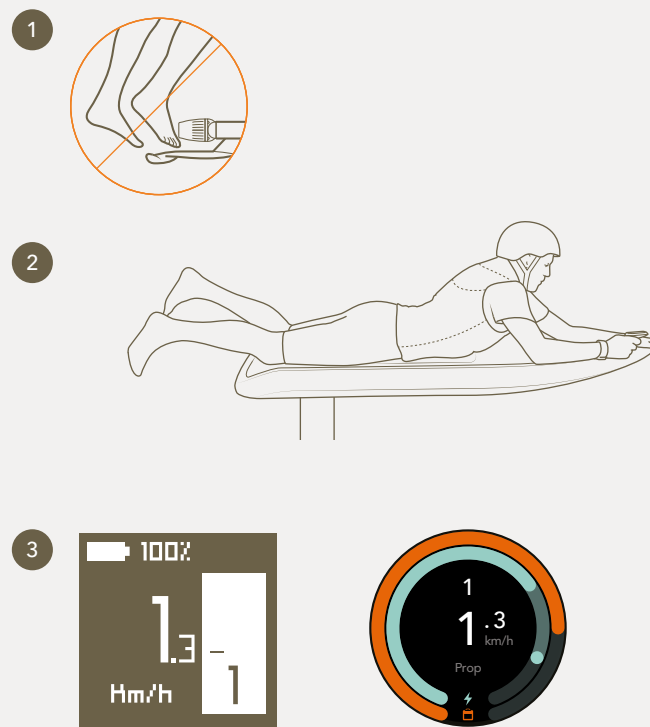

PRO TIP Fliteboard has been designed with a cruise control system in mind. Squeezing the trigger all the way in makes it easier to use your thumb to change the speed (from level 1 to 20). As you accelerate you may need to shuffle forward to keep the nose down.

Getting to your knees

- 1 Once comfortable lying on the board, arming the motor, changing speed and riding the board lying down, it's time to get to your knees.
- 2 Depending on your weight, board and conditions, you may wish to move to your knees on gear 3, 4, 5 or 6. You want to be travelling fast enough that you won't nose dive or sink, but not so fast that you are bouncing over chop, planing quickly or starting to foil. A speed of 6 - 8 km/h on the GPS display on Flite Controller is a good speed for getting to your knees.
- 3 Place both hands on the board, smoothly push your body up and slide both knees under you onto the board. Your knees should be positioned just in front of the lid hinges. Be careful not to put your knees on the hinges themselves.
- 4 Keep your body weight forward to keep the nose down and to prevent the eFoil from coming up too high.

2



3

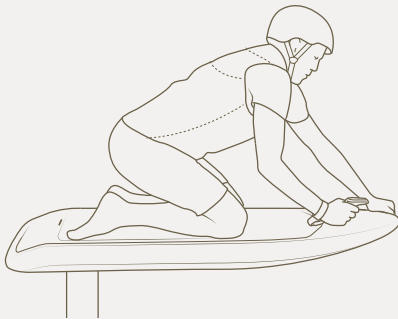

PRO TIP Be careful not to let go of the throttle trigger as you move to your knees. You should practice maintaining a constant speed when changing body positions on the board.

Once you feel ready, you can practice starting to foil on your knees by carefully moving your head and upper body back. As soon as you hear the noise change from the board leaving the water, shift your weight forward again to level off or touch down.

Standing up

Check that you have clear flat water in front of you with no obstacles or other vessels.

Select a speed where the board feels stable. The ideal speed depends on your weight and board choice, but between 8 - 12 km/h is a good speed for standing up.

- 1 While being careful not to let go of the throttle trigger (so you maintain a constant speed) place your front foot in the space in front of your knees. Your toes should be near the front of the foot pad and slightly to one side. (Refer to the diagram in the below PRO TIP)

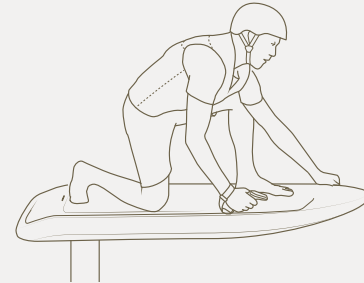

- 2 Take a moment to get your balance. Then, stand up, with as much weight as possible pushing through your front foot. This should feel like standing from a lunge position. Keeping your weight on your front foot keeps the board and nose down, which in turn keeps the foil in the water. Standing up with weight on your rear foot can result in the foil engaging and then an unintended crash.
- 3 Once standing keep your weight forward over your front knee. Your chest and nose should be lined up with, or in front of your front knee.

PRO TIP The ideal body position is with your body twisted forward, with front foot just behind the front of the deck grip, and rear foot 10cm in front of the latches, with both feet hip width apart. This stance is similar to the 'Warrior One' Yoga stance. This riding stance keeps your weight forward allowing good control over the pitching of the board forward, aft, left and right.

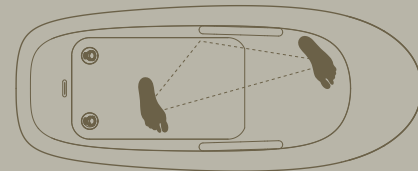

- 4 Once standing, practice slowly adding speed, but always while pushing down hard through your front leg. The wing, motor and your own bow wave will want to push the nose up. Push down hard and practice accelerating to planing speed, with the board flat on the water. Taking your weight off your front foot will increase the lift of the wing, and thus engage the foil, and likely result in a crash until you have learned to balance the board on all axes whilst foiling.

Fliteboarding for the first time

Like learning to ride a bike for the first time, learning to Fliteboard is challenging as it requires your brain to learn a new way to balance. There is also potential for you to fall on the wings if not careful. Wear appropriate safety equipment including a helmet and Impact Vest / PFD, take your time and follow these steps.

Once comfortable standing at medium speeds, practice going faster with as much weight as possible over your front foot. Unlike surfing, you control the board more with your front foot. Weight on your front foot with your body leaning forward is safe, as it keeps the wing and motor submerged in the water. Whenever you become uncomfortable, lean forward toward the nose of the board. This will ensure the board is on the water and stable.

- 1 Practice standing in the rider's stance and gradually increase your speed. The initial goal is to be able to ride at safe foiling speed (so you are in control and still within local laws) with the board still on the water. You do this by keeping your weight forward.
- 2 While planing at the correct speed with your feet in the correct position and the board LEVEL on the water, very gradually start to transfer weight backwards. You will feel slightly less pressure on your front foot and more pressure on the back foot. Do this carefully, with your weight over the centre line of the board and your core engaged.
- 3 As soon as you feel the board leave the water, you are foiling. Lean forward again and touch down. The goal is to foil as LOW as possible for very short sections. Foiling for 5 metres at a time and then touching down again is all you need to do.
- 4 Practice this and your brain will work out the rest. Before long you will be foiling for longer periods and then continuously.

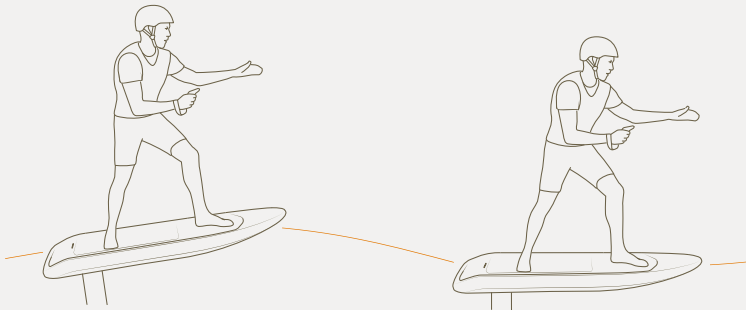

Don't go too high

More pressure on front foot

PRO TIP The safest and easiest way to learn to Fliteboard is to foil low and practice repeated touch and go's. As you foil higher you expose yourself to the risk of a crash where you could hit the wings. You may lose your confidence and learning will take longer.

Fliteboarding pro tips

If you shift your weight too far to one side, it is not possible to recover. Jump away from the board in the direction you are falling. This takes you SAFELY away from the eFoil.

Keep your weight forward and press down through your front knee. Confirm your feet are in the correct position.

Don't vary your speed too quickly, it may unsettle the foil and make balance more difficult. Like an aeroplane, the eFoil wings need a constant speed for smooth flying.

Don't try to foil going too slow. The wings will stall and you may crash.

Don't try to turn whilst foiling until you are very comfortable in a straight line.

Keep the board flat and level.

If you are a light rider, use the settings menu on the Flight Controller to select low power mode.

If you are a heavier rider, select a higher gear before arming the board. This sets the default gear for the next time you arm.

If you are a pro rider, select a high gear before arming and modulate the throttle trigger to control your speed.

Foiling through turns

Turning while foiling requires careful balance on all axes.

Start by doing very wide turns.

As you gain experience you can try tighter turns.

Keep speed constant.

In tight turns you will need to apply more force to your back leg to maintain foil altitude.

All of this might sound complex, but if you keep your weight forward, practice in flat water, maintain constant speed, and take learning step by step, you will likely be foiling in no time.

RAPID RELEASE OF THE TRIGGER CAN CAUSE THE NOSE OF THE BOARD TO SUDDENLY DROP AND MAY CAUSE A CRASH.

Maintenance and storage

READ THROUGH THE ENTIRE STORAGE AND MAINTENANCE INSTRUCTIONS BEFORE STORING YOUR BOARD.

- 1 It is essential that your Fliteboard is serviced as per the 'Maintenance schedule' at the end of this User Guide to retain its high level of performance, safety and reliability, including warranty, as mentioned previously.
- 2 The service intervals are in both hours of ride time or years, whichever comes first.
- 3 The service schedule and intervals assume you will use your Fliteboard in accordance with our guidelines.

Periodic checks

- 1 Ensure that you view our 'Care and Maintenance video' fliteboard.com/video before first using your Fliteboard.
- 2 Ensure that after each session, you visually inspect all elements of your Fliteboard including board, wings, mast, Flitecell and Flite Controller for any damage or water ingress.
- 3 Ensure that you perform the 6 Month Flitecell Checklist located on the Support Page on the website.
- 4 Ensure all connections are clean, free from corrosion and damage after each use.
- 5 Ensure the hinges have been rinsed with fresh water, are clean, free from corrosion and damage after each use.

Maintenance schedule intervals

The hours / years intervals shown in the maintenance schedule section of the User Guide are intended as a guide. If you operate a Fliteschool then supplementary servicing may be necessary.

CAUTION - AVOID LEAVING YOUR FLITEBOARD TIED UP IN MARINAS OR NEAR VESSELS FOR EXTENDED PERIODS OF TIME. ANY EARTH LEAKAGE FROM SURROUNDING VESSELS CAN LEAD TO ACCELERATED CORROSION OF YOUR EFOIL COMPONENTS.

Please contact support@fliteboard.com for any queries or questions.

ICON, PRO, ULTRA, MN, RACE

Post ride

Open the board lid slowly, taking care it doesn't fall on the nose of the board. If the lid is opened too far it may fall and damage the nose of the board.

After each ride, check to see if any water has leaked into the Flitecell cavity.

If so, check the cause of the leak which may include sand present on the sealing surface; a damaged or dislocated seal; damaged hinges or latches; or something obstructing the lid when closed.

Once the Flitecell has been removed ensure that the complete board, including Flitecell compartment, seals, hinges, lid and eFoil are washed thoroughly in fresh water.

Let the board air dry and then wipe down with a clean, dry absorbent cloth.

Regular maintenance

Check the board regularly for damage or cracks. If damage is present have it repaired by a professional surfboard or sailboard repairer.

Inspect the orange mast flange seal regularly for any damage and ensure it is kept clean and free of any sand, grit or dirt.

During daily use ensure that the eFoil is removed from the board and wings from the eFoil at least every three days. Ensure Tef-Gel is reapplied to all screws.

Storage

Ensure that all sand, grit, dirt, and salt residue has been washed off with fresh water, and sufficiently dried. Ensure that the Flitecell has been wiped down with a clean, dry absorbent cloth while switched off.

Ensure the board and deck grip are dry before storage.

Take care not to scratch the board and wings.

Place your Fliteboard in the provided bag, then store in a clean and dry environment.

Keep the board and bag out of the sun.

AIR

Post ride

Wash the inflatable bladder with warm soapy water and dry before storage.

The inflatable bladder can remain inflated, or be deflated to suit your storage preference.

Regular maintenance

The inflatable bladder can be repaired using the supplied repair kit. 15 - 16 PSI is the recommended inflation pressure.

eFoil system

Post ride

Disconnect the Flitecell power cables.

Rinse thoroughly with clean fresh water after every use.

Rinse the inside of the mast (through the notch in the rear of the flange) with fresh water. For carbon masts, also rinse through the hole at the bottom of the fuselage.

Rinse around the mast flange to wash salt away from the board connection area (if keeping the board and eFoil attached).

Regular maintenance

Disassemble the eFoil from the board.

Remove the wing, fuselage cover and tail, and clean thoroughly with fresh soapy water to remove any built-up salt or sand.

Storage

Always store the eFoil in a clean, dry environment.

Flite Controller

Post ride

Rinse Flite Controller in fresh water to clean away salt and debris. Ensure a steady stream of fresh water is applied directly into the trigger housing. While doing so press and depress the trigger numerous times to loosen any sand, grit, debris that may affect its performance.

Peel out the rubber cover on the underside and clean this with fresh water. Ensure this area is dry before replacing the cover.

Regular maintenance

Pre and post season, the 3 torque screws on the underside of the controller can be undone to release the trigger. This will allow you to thoroughly clean and inspect the trigger, spring and magnet.

Storage

Store in a cool dry place, out of the sun.

Flitecell

Post ride

Wipe Flitecell down with a wet cloth (fresh soapy water), Do not spray water directly on the battery.

Flitecell is waterproof but it should remain dry where possible. DO NOT submerge or shower.

Avoid placing Flitecell on the sand, which can make its way into the Flitecell cavity and scratch surfaces.

DO NOT charge the Flitecell immediately after use. The Flitecell temperature may be too high. Allow 30 mins between riding and charging to allow for cooling.

DO NOT clean the Flitecell or charger with denatured alcohol or other flammable solvents.

DO NOT clean the Flitecell or charger with WD-40, citrus cleaners, contact cleaners.

Avoid contact with sunscreens, lubricants, petrol, thread locker and diesel.

IF THE BOARD HAS LEAKED AND / OR THE FLITECELL HAS BEEN SUBMERGED IN WATER, INSPECT FOR WATER INGRESS USING THE SIGHT GLASS LOCATED ON THE SIDE OF THE FLITECELL.

STAND THE FLITECELL UP ON ITS BOTTOM END FOR ONE MINUTE AND THEN PLACE THE FLITECELL ON ITS SIDE WITH THE SIGHT GLASS FACING DOWN FOR ONE MINUTE. INSIDE THE SIGHTGLASS IS A COLOUR CHANGING LABEL WHICH WILL TURN RED IF WATER IS PRESENT. INSPECT THE SIGHT GLASS AND CONFIRM THAT WATER IS NOT PRESENT BEFORE CHARGING AND USING A FLITECELL THAT HAS BEEN IMMERSSED IN WATER.

IF A FLITECELL HAS BEEN DROPPED OR DAMAGED, CONTACT FLITEBOARD IMMEDIATELY AND DO NOT USE THE FLITECELL.

Regular maintenance

1. Examine the charger regularly for damage to the cord, plug, enclosure or other parts. Periodically clean the connections with a Q-tip / cotton tip that has been dampened with isopropyl alcohol (IPA).
2. Inspect all power terminals along with the CANbus receptacle. Periodically clean the terminals with a Q-tip / cotton tip that has been dampened with isopropyl alcohol (IPA).
3. Inspect all screws for heavy rust or corrosion.
4. Inspect sight glass for any water ingress. Sight glass water indicator will have turned pink if water has entered. If water has entered the Flitecell, isolate the unit and contact Fliteboard support immediately.
5. Check the gore vent is in position.
6. Inspect the case of the Flitecell for any cracks or damage. Check the connectors and handles especially of the case.

Storage

1. Keep Flitecell stored out of the reach of children and pets.
2. DO NOT store the Flitecell near heat sources such as a furnace or heater.
3. DO NOT leave the Flitecell inside of a vehicle on hot days.
4. Ideal Flitecell storage temperature between 10°C (50°F) and 25°C (77°F) in a safe, dry place.
5. Do NOT store the Flitecell whilst charging. Disconnect the charger when not in use.
6. DO NOT store the Flitecell fully charged or discharged for a longer period of time.
7. For long or short term storage of Flitecell, a charge state of 40% (1 LED ON indicates 25 - 35% charge) is optimal. Only fully charge the Flitecell when planning a ride. We recommend that you discharge the Flitecell during your final session of the season, remembering to keep it around 40% charge before it goes into storage. Occasionally charging the Flitecell up to 60% SOC every 2 months and letting the Self Balancing technology work away will also prevent any large imbalances or large capacity drops. This can also be sited through the FliteAPP and used to reach the correct SOC%. Connect to the Flitecell on the devices page and charge to designated SOC%
8. After long term storage of your Fliteboard components and before use, you are required to charge the Flitecell and Flite controller to 100% using the supplied Fliteboard chargers. These charging processes may take longer than normal (up to 24 hours) but this gives you time to inspect and perform routine maintenance and checks before your ride.

DO NOT CLEAN THE FLITECELL OR CHARGER WITH WD-40, CITRUS CLEANERS, CONTACT CLEANERS.

AVOID CONTACT WITH SUNSCREENS, LUBRICANTS, PETROL, THREAD LOCKER, AND DIESEL.

Troubleshooting

Issue	Troubleshooting guide
Fliteboard starts to slow or 'limp'	This is a sign your Flitecell is about to run down or overheat. Move out of the water and recharge your Flitecell. Refer to the Flitecell charging instructions (page 22).
Fliteboard turns off while riding	Move out of the water to a safe, dry, clean area. Check the LED on Flitecell to confirm if it still has charge. If it has charge, disconnect and reconnect the Flitecell to see if you can establish a connection. Inspect the Flitecell for water or damage. There should be no water inside the Flitecell housing.
Flite Controller disconnects	Re-arm Flite Controller. See arming instructions (page 40).
Flite Controller unpairs	Re-pair Flite Controller. See pairing instructions (page 41).
Flitecell charger won't connect	Disconnect and reconnect. Contact Fliteboard Customer Support. fliteboard.com/support
Flite Controller won't turn on	Ensure Flite Controller is fully charged. See Flite Controller charging instructions (page 20).
Flite Controller shows a battery or temperature warning	Slow down or decrease power consumption to cool the Flitecell down. Flite Controller will warn you when the Flitecell temperature reaches 55°C and again at 60°C. At 65°C the Flitecell will automatically start to shut down to preserve itself.

Issue	Troubleshooting guide
Flite Controller trigger not functioning	To recalibrate Flite Controller trigger, press and hold the – button (left) and Mode button (bottom) simultaneously. Follow the on-screen instructions.
Water in the Fliteboard cavity	Remove the board from the water. Remove the Flitecell. Dry the board completely. Check the Flitecell for leaks. If the Flitecell has taken in water refer to the section below. Once dried and re-assembled, take care that the Fliteboard cavity seal is properly compressed when closing the Fliteboard lid.
Water in Flitecell	Flitecell has an indicator for water damage. If water has penetrated the casing, regularly check the circular water indicator on the side of your Flitecell. If the sticker has turned red, this means water has penetrated the housing. IF WATER HAS PENETRATED THE FLITECELL, PLEASE SET FLITECELL ASIDE IN A COOL DRY PLACE. DO NOT ATTEMPT TO USE A FLITECELL THAT HAS BEEN WATERLOGGED. CONTACT FLITEBOARD IMMEDIATELY.
Unable to pair Flite Controller	Please ensure no other controllers or boards are switched on. Try again as per pairing instructions (page 41).
Unable to pair Flite Controllers to multiple boards	Do not attempt to pair multiple Flite Controllers to multiple Fliteboards simultaneously. Always pair one at a time.
Reduced ride time	The battery management system (BMS) balances and optimises the Flitecell during each charge cycle. Allow 24 - 48 hours after charging before Flitecell use.

Technical Specifications

Load range		RECOMMENDED	WARRANTY LIMIT
AIR ICON / ICON / MN86	Prop	120kg / 265lbs	120kg / 265lbs
	Jet	100kg / 220lbs	120kg / 265lbs
AIR PRO / PRO / MN60	Prop	100kg / 220lbs	120kg / 265lbs
	Jet	100kg / 220lbs	120kg / 265lbs
ULTRA / L / L2 / L3 / RACE	Prop	90kg / 198lbs	100kg / 220lbs
	Jet	80kg / 176lbs	100kg / 220lbs

Board details	KG	LBS	MEASUREMENTS	LITRES
ULTRA L3	6	13.23	1320 L x 540 W x 107mm D (4'4" x 21 1/4" x 4 3/16")	49
ULTRA L2	6	13.23	1320 L x 540 W x 107mm D (4'4" x 21 1/4" x 4 3/16")	49
ULTRA L	8	17.6	1299 L x 580 W x 110mm D (4'2" x 22 5/16" x 4 21/64")	57
ULTRA	9	19.8	1299 L x 580 W x 110mm D (4'2" x 22 5/16" x 4 21/64")	57
ICON Carbon	11.9	26.2	1735 L x 714 W x 118mm D (5'8" x 28 7/64" x 4 41/64")	100
ICON Soft Top 2	12.8	28.2	1735 L x 714 W x 118mm D (5'8" x 28 7/64" x 4 41/64")	100
ICON Fibreglass	12.8	28.2	1735 L x 714 W x 118mm D (5'8" x 28 7/64" x 4 41/64")	100
PRO Carbon	9.3	20.5	1524 L x 624 W x 109mm D (5'0" x 24 9/16" x 4 9/16")	67
PRO Soft Top 2	10	22	1524 L x 624 W x 109mm D (5'0" x 24 9/16" x 4 9/16")	67
PRO Fibreglass	10	22	1524 L x 624 W x 109mm D (5'0" x 24 9/16" x 4 9/16")	67
RACE	7.2	15.9	1470 L x 520 W x 107mm D (4'10" x 20 1/2" x 4 3/16")	58
AIR PRO	11	24.3	1580 L x 647 W x 110mm D (5'2" x 25 1/2" x 4 5/16")	80
AIR ICON	12	26.5	1730 L x 698 W x 115mm D (5'8" x 27 1/2" x 4 1/2")	100
MN60	7.2	16	1373 L x 560 W x 110mm D (4'6" x 25" x 4 21/64")	60
MN86	9.2	20	1628 L x 660 W x 110mm D (5'4" x 26" x 4 21/64")	86

WEIGHTS & MEASUREMENTS MAY VARY

Ride time 85kg/210lbs rider Up to 1 hr 30 min (Flitecell Explore)
Using a large wing at slow foiling speed, it's possible to ride for over 2 hours.

AIR Type	Inflatable
Pressure	15 - 16 PSI

eFoil systems with Flite Prop

Input power	5,000 Watts
Max output power at shaft	3,600 Watts
Nominal voltage	52V
Maximum current	100A
Motor type	Brushless
Motor speed	4500 rpm peak
Protections	Overheating, overcurrent
Propeller diameter	142mm
Propeller guard diameter	155mm

eFoil systems with Flite Jet 2

Input power	5,000 Watts
Max output power at shaft	3,600 Watts
Nominal voltage	52V
Maximum current	100A
Motor type	Brushless
Motor speed	10500 rpm peak
Protections	Overheating, overcurrent
Jet diameter	88mm

MN Wave Folding Prop

Input power	3,000 Watts
Max output power at shaft	2,250 Watts
Nominal voltage	52V
Maximum current	60A
Motor type	Brushless
Motor speed	3500 rpm peak
Protections	Overheating, overcurrent
Propeller diameter	135mm

Flite Controller

Communication type	Bluetooth
Speed control	20 virtual gears
Rated cycles	1000 charge cycles
Protection grade	IP67
Runtime	

Flite Controller
Standby 3+ months
Operating 24 hrs

MN Flite Controller
Standby 3+ months
Operating 8 hrs

Flitecell Fast Charger

Charging current	25A
Charge time	1 hr 45 min Flitecell Explore 1 hr 15 min Flitecell Sport 50 min Flitecell Nano

Flitecell Charger

Charging current	6A
Charge time	7 hr 30 min Flitecell Explore 5 hr 30 min Flitecell Sport 3 hr Flitecell Nano

Flitecell Explore

Size	390mm x 305mm x 80mm (15" x 12" x 3")
Capacity	40Ah / 2016Wh
Weight	14.5kg / 32lbs
Protection	IP67
Max charge voltage	58.8V
Min voltage	42V
Nominal voltage	50.4V
Rated continuous discharge current	100A
Rated charge current	25A
Rated cycles >80% capacity	400 Cycles / 2 years
Temperature discharge limits	0 - 70°C 32 - 158°F
Temperature charge limits	0 - 50°C 32 - 122°F
Communication	Bluetooth Low Energy
BMS critical functions	Balancing, Over-temperature (Charge / Discharge) Over-current, short-circuit protection, reverse polarity and over & under voltage.
Other safety	3 levels of fusing adds redundancy if BMS failure occurs. Conformal / resin coatings used on PCB's. Phase Changing Material between cells and sight glass to check for leaks.
Shipping and transport	Flitecell (batteries) are considered dangerous goods and must not be shipped without working with a dangerous goods shipping specialist. Shipping batteries marked as normal goods without informing the shipping party is illegal and dangerous. The Material Safety Data Sheet (MSDS) is required for shipping the batteries.

ULTRA L3, AIR ICON, AIR PRO AND ULTRA L2 ARE NOT COMPATIBLE WITH FLITECELL EXPLORE.

Flitecell Sport

Size	305mm x 305mm x 80mm (12" x 12" x 3")
Capacity	29.4Ah / 1482Wh
Weight	10.6kg / 23.4lbs
Protection	IP67
Max charge voltage	58.8V
Min voltage	42V
Nominal voltage	50.4V
Rated continuous discharge current	100A
Rated charge current	25A
Rated cycles >80% capacity	400 Cycles / 2 years
Temperature discharge limits	0 - 70°C 32 - 158°F
Temperature charge limits	0 - 50°C 32 - 122°F
Communication	Bluetooth Low Energy
BMS critical functions	Balancing, Over-temperature (Charge / Discharge) Over-current, short-circuit protection, reverse polarity and over & under voltage.
Other safety	3 levels of fusing adds redundancy if BMS failure occurs. Conformal / resin coatings used on PCB's. Phase Changing Material between cells and sight glass to check for leaks.
Shipping and transport	Flitecell (batteries) are considered dangerous goods and must not be shipped without working with a dangerous goods shipping specialist. Shipping batteries marked as normal goods without informing the shipping party is illegal and dangerous. The Material Safety Data Sheet (MSDS) is required for shipping the batteries.

Flitecell Nano

Size	218mm x 305mm x 80mm (8 ½" x 12" x 3")
Capacity	16.8Ah / 806Wh
Weight	6.2kg / 13.7lbs
Protection	IP67
Max charge voltage	58.8V
Min voltage	42V
Nominal voltage	50.4V
Rated continuous discharge current	100A
Rated charge current	25A
Rated cycles >80% capacity	400 Cycles / 2 years
Temperature discharge limits	0 - 70°C 32 - 158°F
Temperature charge limits	0 - 50°C 32 - 122°F
Communication	Bluetooth Low Energy
BMS critical functions	Balancing, Over-temperature (Charge / Discharge) Over-current, short-circuit protection, reverse polarity and over & under voltage.
Other safety	3 levels of fusing adds redundancy if BMS failure occurs. Conformal / resin coatings used on PCB's. Phase Changing Material between cells and sight glass to check for leaks.
Shipping and transport	Flitecell (batteries) are considered dangerous goods and must not be shipped without working with a dangerous goods shipping specialist. Shipping batteries marked as normal goods without informing the shipping party is illegal and dangerous. The Material Safety Data Sheet (MSDS) is required for shipping the batteries.

Warranty registration / Details of purchase

Register your product using Flite App fliteboard.com/app

WE RECOMMEND USING FLITE APP TO ENSURE YOUR EFOIL AND FLITE CONTROLLER ALWAYS HAVE THE LATEST SOFTWARE

Customer name

Business name
(if applicable)

Country & State

Purchased from

Date of purchase

Board type & serial number

eFoil type & serial number

Propulsion Folding Prop Flite Propeller True Glide Flite Jet 2

Flitecell type Explore Sport Nano

Flitecell serial number(s)

Flitecell Charger type & serial number

Flite Controller type & serial number

Maintenance schedule

FIRST 100 HOURS / 1 YEAR SERVICE

WHICHEVER COMES FIRST

Inspected

Replaced

Mast

Seals

Fuselage

Oil

Flitebox

Flitebox Gore vent

Cables

Cables

Prop Guard

Prop Guard

Propeller

Propeller

Flite Jet 2

Flite Jet 2

Flitecell health

Anode

Flite Controller

Flite Controller

MN Flite Controller

MN Flite Controller

Comments

eFoil Hours of use

Date

Name of Technician

Signature of Technician

Flite Service Dealer

Maintenance schedule

200 HOURS / 2 YEAR SERVICE

WHICHEVER COMES FIRST

Inspected	Replaced
<input type="checkbox"/> Mast	<input type="checkbox"/> Seals
<input type="checkbox"/> Fuselage	<input type="checkbox"/> Oil
<input type="checkbox"/> Flitebox	<input type="checkbox"/> Flitebox Gore vent
<input type="checkbox"/> Cables	<input type="checkbox"/> Cables
<input type="checkbox"/> Prop Guard	<input type="checkbox"/> Prop Guard
<input type="checkbox"/> Propeller	<input type="checkbox"/> Propeller
<input type="checkbox"/> Flite Jet 2	<input type="checkbox"/> Flite Jet 2
<input type="checkbox"/> Flitecell health	<input type="checkbox"/> Anode
<input type="checkbox"/> Flite Controller	<input type="checkbox"/> Flite Controller
<input type="checkbox"/> MN Flite Controller	<input type="checkbox"/> MN Flite Controller

Comments

eFoil Hours of use **Date**

Name of Technician

Signature of Technician

Flite Service Dealer

Maintenance schedule

300 HOURS / 3 YEAR SERVICE

WHICHEVER COMES FIRST

Inspected	Replaced
<input type="checkbox"/> Mast	<input type="checkbox"/> Seals
<input type="checkbox"/> Fuselage	<input type="checkbox"/> Oil
<input type="checkbox"/> Flitebox	<input type="checkbox"/> Flitebox Gore vent
<input type="checkbox"/> Cables	<input type="checkbox"/> Cables
<input type="checkbox"/> Prop Guard	<input type="checkbox"/> Prop Guard
<input type="checkbox"/> Propeller	<input type="checkbox"/> Propeller
<input type="checkbox"/> Flite Jet 2	<input type="checkbox"/> Flite Jet 2
<input type="checkbox"/> Flitecell health	<input type="checkbox"/> Anode
<input type="checkbox"/> Flite Controller	<input type="checkbox"/> Flite Controller
<input type="checkbox"/> MN Flite Controller	<input type="checkbox"/> MN Flite Controller

Comments

eFoil Hours of use **Date**

Name of Technician

Signature of Technician

Flite Service Dealer

Maintenance schedule

400 HOURS / 4 YEAR SERVICE

WHICHEVER COMES FIRST

Inspected

Mast

Fuselage

Flitebox

Cables

Prop Guard

Propeller

Flite Jet 2

Flitecell health

Flite Controller

MN Flite Controller

Replaced

Seals

Oil

Flitebox Gore vent

Cables

Prop Guard

Propeller

Flite Jet 2

Anode

Flite Controller

MN Flite Controller

Comments

eFoil Hours of use

Date

Name of Technician

Signature of Technician

Flite Service Dealer

Maintenance schedule

500 HOURS / 5 YEAR SERVICE

WHICHEVER COMES FIRST

Inspected

Mast

Fuselage

Flitebox

Cables

Prop Guard

Propeller

Flite Jet 2

Flitecell health

Flite Controller

MN Flite Controller

Replaced

Seals

Oil

Flitebox Gore vent

Cables

Prop Guard

Propeller

Flite Jet 2

Anode

Flite Controller

MN Flite Controller

Comments

eFoil Hours of use

Date

Name of Technician

Signature of Technician

Flite Service Dealer

Congratulations on becoming a Fliteboard owner.

Now it's time to get out there and experience the freedom of Flite.

Fastener reference guide

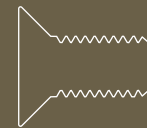

Conical wing
2 x M8 x 18mm

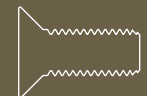

Fuselage tail
1 x M6 x 16mm

Flux Stabiliser
2 x M6 x 16mm

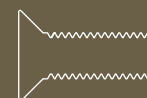

Stabiliser
2 x M6 x 20mm

Mast Flange
4 x M6 x 20mm

